

Chapter 2

Electrostatics

2.1 The Electric Field

2.1.1 Introduction

The fundamental problem electromagnetic theory hopes to solve is this (Fig. 2.1): We have some electric charges, q_1, q_2, q_3, \dots (call them **source charges**); what force do they exert on another charge, Q (call it the **test charge**)? The positions of the source charges are *given* (as functions of time); the trajectory of the test particle is *to be calculated*. In general, both the source charges and the test charge are in motion.

The solution to this problem is facilitated by the **principle of superposition**, which states that the interaction between any two charges is completely unaffected by the presence of others. This means that to determine the force on Q , we can first compute the force F_1 , due to q_1 alone (ignoring all the others); then we compute the force F_2 , due to q_2 alone; and so on. Finally, we take the vector sum of all these individual forces: $F = F_1 + F_2 + F_3 + \dots$. Thus, if we can find the force on Q due to a *single* source charge q , we are, in principle, done (the rest is just a question of repeating the same operation over and over, and adding it all up).¹

Well, at first sight this sounds very easy: Why don't I just write down the formula for the force on Q due to q , and be done with it? I *could*, and in Chapter 10 I shall, but you would be shocked to see it at this stage, for not only does the force on Q depend on the separation distance r between the charges (Fig. 2.2), it also depends on *both* their velocities and on the *acceleration* of q . Moreover, it is not the position, velocity, and acceleration of q *right now* that matter: Electromagnetic "news" travels at the speed of light, so what concerns Q is the position, velocity, and acceleration q *had* at some earlier time, when the message left.

¹ The principle of superposition may seem "obvious" to you, but it did not *have* to be so simple: if the electromagnetic force were proportional to the *square* of the total source charge, for instance, the principle of superposition would not hold, since $(q_1 + q_2)^2 \neq q_1^2 + q_2^2$ (there would be "cross terms" to consider). Superposition is not a *logical necessity*, but an *experimental fact*.

2.1. THE ELECTRIC FIELD

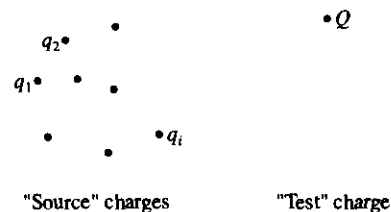

Figure 2.1

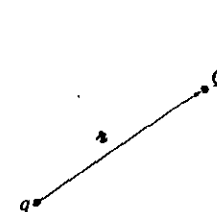

Figure 2.2

Therefore, in spite of the fact that the basic question ("What is the force on Q due to q ?") is easy to state, it does not pay to confront it head on; rather, we shall go at it by stages. In the meantime, the theory we develop will permit the solution of more subtle electromagnetic problems that do not present themselves in quite this simple format. To begin with, we shall consider the special case of **electrostatics** in which all the *source charges are stationary* (though the test charge may be moving).

2.1.2 Coulomb's Law

What is the force on a test charge Q due to a single point charge q which is at *rest* a distance r away? The answer (based on experiments) is given by **Coulomb's law**:

$$\mathbf{F} = \frac{1}{4\pi\epsilon_0} \frac{qQ}{r^2} \hat{\mathbf{r}} \quad (2.1)$$

The constant ϵ_0 is called the **permittivity of free space**. In SI units, where force is in Newtons (N), distance in meters (m), and charge in coulombs (C),

$$\epsilon_0 = 8.85 \times 10^{-12} \frac{\text{C}^2}{\text{N} \cdot \text{m}^2}$$

In words, the force is proportional to the product of the charges and inversely proportional to the square of the separation distance. As always (Sect. 1.1.4), $\hat{\mathbf{r}}$ is the separation vector from \mathbf{r}' (the location of q) to \mathbf{r} (the location of Q):

$$\hat{\mathbf{r}} = \mathbf{r} - \mathbf{r}' \quad (2.2)$$

r is its magnitude, and $\hat{\mathbf{r}}$ is its direction. The force points along the line from q to Q ; it is repulsive if q and Q have the same sign, and attractive if their signs are opposite.

Coulomb's law and the principle of superposition constitute the physical input for electrostatics—the rest, except for some special properties of matter, is mathematical elaboration of these fundamental rules.

Problem 2.1

- (a) Twelve equal charges, q , are situated at the corners of a regular 12-sided polygon (for instance, one on each numeral of a clock face). What is the net force on a test charge Q at the center?
- (b) Suppose *one* of the 12 q 's is removed (the one at "6 o'clock"). What is the force on Q ? Explain your reasoning carefully.
- (c) Now 13 equal charges, q , are placed at the corners of a regular 13-sided polygon. What is the force on a test charge Q at the center?
- (d) If one of the 13 q 's is removed, what is the force on Q ? Explain your reasoning.

2.1.3 The Electric Field

If we have *several* point charges q_1, q_2, \dots, q_n , at distances r_1, r_2, \dots, r_n from Q , the total force on Q is evidently

$$\begin{aligned} \mathbf{F} &= \mathbf{F}_1 + \mathbf{F}_2 + \dots = \frac{1}{4\pi\epsilon_0} \left(\frac{q_1 Q}{r_1^2} \hat{\mathbf{r}}_1 + \frac{q_2 Q}{r_2^2} \hat{\mathbf{r}}_2 + \dots \right) \\ &= \frac{Q}{4\pi\epsilon_0} \left(\frac{q_1 \hat{\mathbf{r}}_1}{r_1^2} + \frac{q_2 \hat{\mathbf{r}}_2}{r_2^2} + \frac{q_3 \hat{\mathbf{r}}_3}{r_3^2} + \dots \right), \end{aligned} \quad (2.3)$$

or

$$\boxed{\mathbf{F} = QE}, \quad (2.3)$$

where

$$\mathbf{E}(\mathbf{r}) \equiv \frac{1}{4\pi\epsilon_0} \sum_{i=1}^n \frac{q_i \hat{\mathbf{r}}_i}{r_i^2}. \quad (2.4)$$

\mathbf{E} is called the **electric field** of the source charges. Notice that it is a function of position (\mathbf{r}), because the separation vectors $\hat{\mathbf{r}}_i$ depend on the location of the field point P (Fig. 2.3). But it makes no reference to the test charge Q . The electric field is a vector quantity that varies

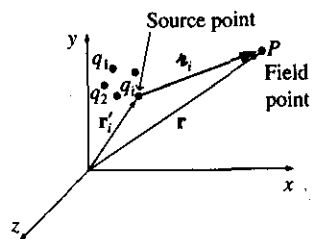

Figure 2.3

2.1. THE ELECTRIC FIELD

from point to point and is determined by the configuration of source charges; physically, $\mathbf{E}(\mathbf{r})$ is the force per unit charge that would be exerted on a test charge, if you were to place one at P .

What exactly *is* an electric field? I have deliberately begun with what you might call the "minimal" interpretation of \mathbf{E} , as an intermediate step in the calculation of electric forces. But I encourage you to think of the field as a "real" physical entity, filling the space in the neighborhood of any electric charge. Maxwell himself came to believe that electric and magnetic fields represented actual stresses and strains in an invisible primordial jellylike "ether." Special relativity has forced us to abandon the notion of ether, and with it Maxwell's mechanical interpretation of electromagnetic fields. (It is even possible, though cumbersome, to formulate classical electrodynamics as an "action-at-a-distance" theory, and dispense with the field concept altogether.) I can't tell you, then, what a field *is*—only how to calculate it and what it can do for you once you've got it.

Problem 2.2

- (a) Find the electric field (magnitude and direction) a distance z above the midpoint between two equal charges, q , a distance d apart (Fig. 2.4). Check that your result is consistent with what you'd expect when $z \gg d$.
- (b) Repeat part (a), only this time make the right-hand charge $-q$ instead of $+q$.

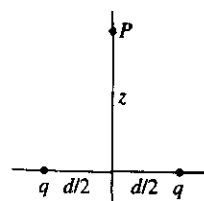

Figure 2.4

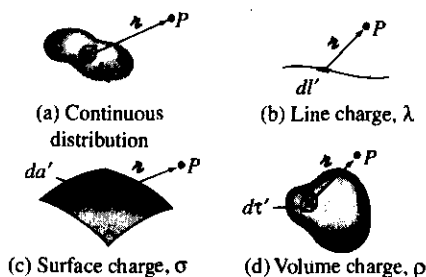

Figure 2.5

2.1.4 Continuous Charge Distributions

Our definition of the electric field (Eq. 2.4), assumes that the source of the field is a collection of discrete point charges q_i . If, instead, the charge is distributed continuously over some region, the sum becomes an integral (Fig. 2.5a):

$$\mathbf{E}(\mathbf{r}) = \frac{1}{4\pi\epsilon_0} \int \frac{1}{r^2} \hat{\mathbf{r}} dq. \quad (2.5)$$

If the charge is spread out along a *line* (Fig. 2.5b), with charge-per-unit-length λ , then $dq = \lambda dl'$ (where dl' is an element of length along the line); if the charge is smeared out over a *surface* (Fig. 2.5c), with charge-per-unit-area σ , then $dq = \sigma da'$ (where da' is an element of area on the surface); and if the charge fills a *volume* (Fig. 2.5d), with charge-per-unit-volume ρ , then $dq = \rho d\tau'$ (where $d\tau'$ is an element of volume):

$$dq \rightarrow \lambda dl' \sim \sigma da' \sim \rho d\tau'.$$

Thus the electric field of a line charge is

$$\mathbf{E}(\mathbf{r}) = \frac{1}{4\pi\epsilon_0} \int_P \frac{\lambda(\mathbf{r}')}{r^2} \hat{\mathbf{r}} dl'; \quad (2.6)$$

for a surface charge,

$$\mathbf{E}(\mathbf{r}) = \frac{1}{4\pi\epsilon_0} \int_S \frac{\sigma(\mathbf{r}')}{r^2} \hat{\mathbf{r}} da'; \quad (2.7)$$

and for a volume charge,

$$\mathbf{E}(\mathbf{r}) = \frac{1}{4\pi\epsilon_0} \int_V \frac{\rho(\mathbf{r}')}{r^2} \hat{\mathbf{r}} d\tau'. \quad (2.8)$$

Equation 2.8 itself is often referred to as “Coulomb’s law,” because it is such a short step from the original (2.1), and because a volume charge is in a sense the most general and realistic case. Please note carefully the meaning of $\hat{\mathbf{r}}$ in these formulas. Originally, in Eq. 2.4, $\hat{\mathbf{r}}_i$ stood for the vector from the source charge q_i to the field point \mathbf{r} . Correspondingly, in Eqs. 2.5–2.8, $\hat{\mathbf{r}}$ is the vector from dq (therefore from dl' , da' , or $d\tau'$) to the field point \mathbf{r} .²

Example 2.1

Find the electric field a distance z above the midpoint of a straight line segment of length $2L$, which carries a uniform line charge λ (Fig. 2.6).

Solution: It is advantageous to chop the line up into symmetrically placed pairs (at $\pm x$), for then the horizontal components of the two fields cancel, and the net field of the pair is

$$d\mathbf{E} = 2 \frac{1}{4\pi\epsilon_0} \left(\frac{\lambda dx}{r^2} \right) \cos\theta \hat{\mathbf{z}}.$$

²Warning: The unit vector $\hat{\mathbf{r}}$ is *not* constant; its *direction* depends on the source point \mathbf{r}' , and hence it *cannot* be taken outside the integrals 2.5–2.8. In practice, you must work with *Cartesian* components ($\hat{\mathbf{x}}$, $\hat{\mathbf{y}}$, $\hat{\mathbf{z}}$ are constant, and *do* come out), even if you use curvilinear coordinates to perform the integration.

2.1. THE ELECTRIC FIELD

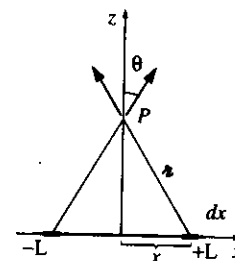

Figure 2.6

Here $\cos\theta = z/r$, $r = \sqrt{z^2 + x^2}$, and x runs from 0 to L :

$$\begin{aligned} E &= \frac{1}{4\pi\epsilon_0} \int_0^L \frac{2\lambda z}{(z^2 + x^2)^{3/2}} dx \\ &= \frac{2\lambda z}{4\pi\epsilon_0} \left[\frac{x}{z^2 \sqrt{z^2 + x^2}} \right]_0^L \\ &= \frac{1}{4\pi\epsilon_0} \frac{2\lambda L}{z \sqrt{z^2 + L^2}}, \end{aligned}$$

and it aims in the z -direction.

For points far from the line ($z \gg L$), this result simplifies:

$$E \cong \frac{1}{4\pi\epsilon_0} \frac{2\lambda L}{z^2},$$

which makes sense: From far away the line “looks” like a point charge $q = 2\lambda L$, so the field reduces to that of point charge $q/(4\pi\epsilon_0 z^2)$. In the limit $L \rightarrow \infty$, on the other hand, we obtain the field of an infinite straight wire:

$$E = \frac{1}{4\pi\epsilon_0} \frac{2\lambda}{z};$$

or, more generally,

$$E = \frac{1}{4\pi\epsilon_0} \frac{2\lambda}{s}, \quad (2.9)$$

where s is the distance from the wire.

Problem 2.3 Find the electric field a distance z above one end of a straight line segment of length L (Fig. 2.7), which carries a uniform line charge λ . Check that your formula is consistent with what you would expect for the case $z \gg L$.

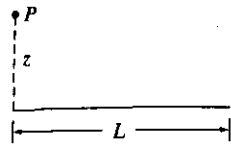

Figure 2.7

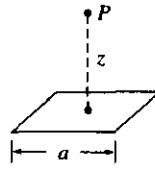

Figure 2.8

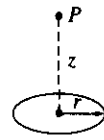

Figure 2.9

Problem 2.4 Find the electric field a distance z above the center of a square loop (side a) carrying uniform line charge λ (Fig. 2.8). [Hint: Use the result of Ex. 2.1.]

Problem 2.5 Find the electric field a distance z above the center of a circular loop of radius r (Fig. 2.9), which carries a uniform line charge λ .

Problem 2.6 Find the electric field a distance z above the center of a flat circular disk of radius R (Fig. 2.10), which carries a uniform surface charge σ . What does your formula give in the limit $R \rightarrow \infty$? Also check the case $z \gg R$.

Problem 2.7 Find the electric field a distance z from the center of a spherical surface of radius R (Fig. 2.11), which carries a uniform charge density σ . Treat the case $z < R$ (inside) as well as $z > R$ (outside). Express your answers in terms of the total charge q on the sphere. [Hint: Use the law of cosines to write z in terms of R and θ . Be sure to take the *positive* square root: $\sqrt{R^2 + z^2 - 2Rz} = (R - z)$ if $R > z$, but it's $(z - R)$ if $R < z$.]

Problem 2.8 Use your result in Prob. 2.7 to find the field inside and outside a sphere of radius R , which carries a uniform volume charge density ρ . Express your answers in terms of the total charge of the sphere, q . Draw a graph of $|\mathbf{E}|$ as a function of the distance from the center.

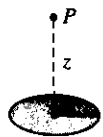

Figure 2.10

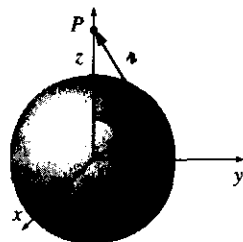

Figure 2.11

2.2 Divergence and Curl of Electrostatic Fields

2.2.1 Field Lines, Flux, and Gauss's Law

In principle, we are *done* with the subject of electrostatics. Equation 2.8 tells us how to compute the field of a charge distribution, and Eq. 2.3 tells us what the force on a charge Q placed in this field will be. Unfortunately, as you may have discovered in working Prob. 2.7, the integrals involved in computing \mathbf{E} can be formidable, even for reasonably simple charge distributions. Much of the rest of electrostatics is devoted to assembling a bag of tools and tricks for *avoiding* these integrals. It all begins with the divergence and curl of \mathbf{E} . I shall calculate the divergence of \mathbf{E} directly from Eq. 2.8, in Sect. 2.2.2, but first I want to show you a more qualitative, and perhaps more illuminating, intuitive approach.

Let's begin with the simplest possible case: a single point charge q , situated at the origin:

$$\mathbf{E}(\mathbf{r}) = \frac{1}{4\pi\epsilon_0} \frac{q}{r^2} \hat{\mathbf{r}}. \quad (2.10)$$

To get a "feel" for this field, I might sketch a few representative vectors, as in Fig. 2.12a. Because the field falls off like $1/r^2$, the vectors get shorter as you go farther away from the origin; they always point radially outward. But there is a nicer way to represent this field, and that's to connect up the arrows, to form **field lines** (Fig. 2.12b). You might think that I have thereby thrown away information about the *strength* of the field, which was contained in the length of the arrows. But actually I have not. The magnitude of the field is indicated by the *density* of the field lines: it's strong near the center where the field lines are close together, and weak farther out, where they are relatively far apart.

In truth, the field-line diagram is deceptive, when I draw it on a two-dimensional surface, for the density of lines passing through a circle of radius r is the total number divided by the circumference ($n/2\pi r$), which goes like $(1/r)$, not $(1/r^2)$. But if you imagine the model in three dimensions (a pincushion with needles sticking out in all directions), then the density of lines is the total number divided by the area of the sphere ($n/4\pi r^2$), which *does* go like $(1/r^2)$.

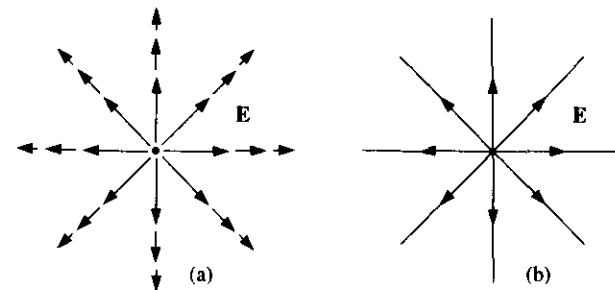
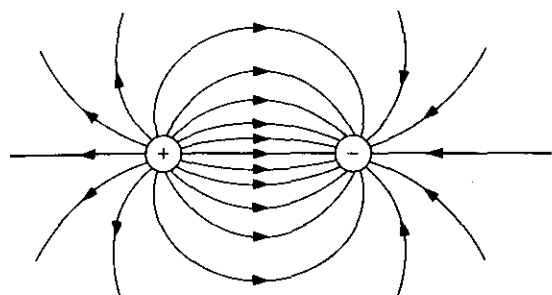

Figure 2.12



Equal but opposite charges

Figure 2.13

Such diagrams are also convenient for representing more complicated fields. Of course, the number of lines you draw depends on how energetic you are (and how sharp your pencil is), though you ought to include enough to get an accurate sense of the field, and you must be consistent: If charge q gets 8 lines, then $2q$ deserves 16. And you must space them fairly—they emanate from a point charge symmetrically in all directions. Field lines begin on positive charges and end on negative ones; they cannot simply terminate in midair, though they may extend out to infinity. Moreover, field lines can never cross—at the intersection, the field would have two different directions at once! With all this in mind, it is easy to sketch the field of any simple configuration of point charges: Begin by drawing the lines in the neighborhood of each charge, and then connect them up or extend them to infinity (Figs. 2.13 and 2.14).

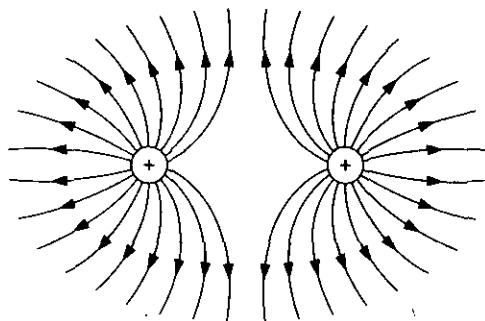

Equal charges

Figure 2.14

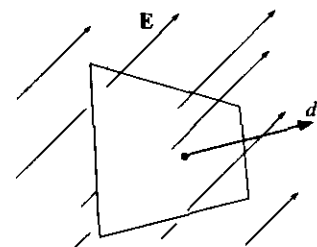

Figure 2.15

In this model the *flux* of \mathbf{E} through a surface \mathcal{S} ,

$$\Phi_E \equiv \int_{\mathcal{S}} \mathbf{E} \cdot d\mathbf{a}, \quad (2.11)$$

is a measure of the “number of field lines” passing through \mathcal{S} . I put this in quotes because of course we can only draw a representative *sample* of the field lines—the *total* number would be infinite. But *for a given sampling rate* the flux is *proportional* to the number of lines drawn, because the field strength, remember, is proportional to the density of field lines (the number per unit area), and hence $\mathbf{E} \cdot d\mathbf{a}$ is proportional to the number of lines passing through the infinitesimal area $d\mathbf{a}$. (The dot product picks out the component of $d\mathbf{a}$ along the direction of \mathbf{E} , as indicated in Fig. 2.15. It is only the area *in the plane perpendicular to \mathbf{E}* that we have in mind when we say that the density of field lines is the number per unit area.)

This suggests that the flux through any *closed* surface is a measure of the total charge inside. For the field lines that originate on a positive charge must either pass out through the surface or else terminate on a negative charge inside (Fig. 2.16a). On the other hand, a charge *outside* the surface will contribute nothing to the total flux, since its field lines pass in one side and out the other (Fig. 2.16b). This is the *essence* of **Gauss’s law**. Now let’s make it quantitative.

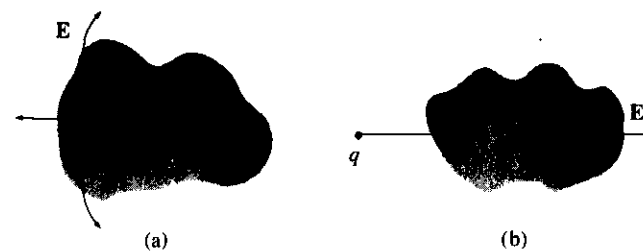

Figure 2.16

In the case of a point charge q at the origin, the flux of \mathbf{E} through a sphere of radius r is

$$\oint \mathbf{E} \cdot d\mathbf{a} = \int \frac{1}{4\pi\epsilon_0} \left(\frac{q}{r^2} \hat{\mathbf{r}} \right) \cdot (r^2 \sin\theta d\theta d\phi \hat{\mathbf{r}}) = \frac{1}{\epsilon_0} q. \quad (2.12)$$

Notice that the radius of the sphere cancels out, for while the surface area goes up as r^2 , the field goes down as $1/r^2$, and so the product is constant. In terms of the field-line picture, this makes good sense, since the same number of field lines passes through any sphere centered at the origin, regardless of its size. In fact, it didn't have to be a sphere—any closed surface, whatever its shape, would trap the same number of field lines. Evidently *the flux through any surface enclosing the charge is q/ϵ_0* .

Now suppose that instead of a single charge at the origin, we have a bunch of charges scattered about. According to the principle of superposition, the total field is the (vector) sum of all the individual fields:

$$\mathbf{E} = \sum_{i=1}^n \mathbf{E}_i.$$

The flux through a surface that encloses them all, then, is

$$\oint \mathbf{E} \cdot d\mathbf{a} = \sum_{i=1}^n \left(\oint \mathbf{E}_i \cdot d\mathbf{a} \right) = \sum_{i=1}^n \left(\frac{1}{\epsilon_0} q_i \right).$$

For any closed surface, then,

$$\oint_S \mathbf{E} \cdot d\mathbf{a} = \frac{1}{\epsilon_0} Q_{\text{enc}}, \quad (2.13)$$

where Q_{enc} is the total charge enclosed within the surface. This is the quantitative statement of Gauss's law. Although it contains no information that was not already present in Coulomb's law and the principle of superposition, it is of almost magical power, as you will see in Sect. 2.2.3. Notice that it all hinges on the $1/r^2$ character of Coulomb's law; without that the crucial cancellation of the r 's in Eq. 2.12 would not take place, and the total flux of \mathbf{E} would depend on the surface chosen, not merely on the total charge enclosed. Other $1/r^2$ forces (I am thinking particularly of Newton's law of universal gravitation) will obey "Gauss's laws" of their own, and the applications we develop here carry over directly.

As it stands, Gauss's law is an *integral* equation, but we can readily turn it into a *differential* one, by applying the divergence theorem:

$$\oint_S \mathbf{E} \cdot d\mathbf{a} = \int_V (\nabla \cdot \mathbf{E}) d\tau.$$

Rewriting Q_{enc} in terms of the charge density ρ , we have

$$Q_{\text{enc}} = \int_V \rho d\tau.$$

So Gauss's law becomes

$$\int_V (\nabla \cdot \mathbf{E}) d\tau = \int_V \left(\frac{\rho}{\epsilon_0} \right) d\tau.$$

And since this holds for *any* volume, the integrands must be equal:

$$\nabla \cdot \mathbf{E} = \frac{1}{\epsilon_0} \rho. \quad (2.14)$$

Equation 2.14 carries the same message as Eq. 2.13; it is **Gauss's law in differential form**. The differential version is tidier, but the integral form has the advantage in that it accommodates point, line, and surface charges more naturally.

Problem 2.9 Suppose the electric field in some region is found to be $\mathbf{E} = kr^3 \hat{\mathbf{r}}$, in spherical coordinates (k is some constant).

(a) Find the charge density ρ .

(b) Find the total charge contained in a sphere of radius R , centered at the origin. (Do it two different ways.)

Problem 2.10 A charge q sits at the back corner of a cube, as shown in Fig. 2.17. What is the flux of \mathbf{E} through the shaded side?

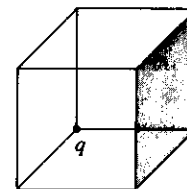

Figure 2.17

2.2.2 The Divergence of \mathbf{E}

Let's go back, now, and calculate the divergence of \mathbf{E} directly from Eq. 2.8:

$$\mathbf{E}(\mathbf{r}) = \frac{1}{4\pi\epsilon_0} \int_{\text{all space}} \frac{\hat{\mathbf{r}}}{r^2} \rho(\mathbf{r}') d\tau'. \quad (2.15)$$

(Originally the integration was over the volume occupied by the charge, but I may as well extend it to all space, since $\rho = 0$ in the exterior region anyway.) Noting that the

r -dependence is contained in $\mathbf{z} = \mathbf{r} - \mathbf{r}'$, we have

$$\nabla \cdot \mathbf{E} = \frac{1}{4\pi\epsilon_0} \int \nabla \cdot \left(\frac{\hat{\mathbf{z}}}{z^2} \right) \rho(\mathbf{r}') d\tau'.$$

This is precisely the divergence we calculated in Eq. 1.100:

$$\nabla \cdot \left(\frac{\hat{\mathbf{z}}}{z^2} \right) = 4\pi\delta^3(\mathbf{z}).$$

Thus

$$\nabla \cdot \mathbf{E} = \frac{1}{4\pi\epsilon_0} \int 4\pi\delta^3(\mathbf{r} - \mathbf{r}') \rho(\mathbf{r}') d\tau' = \frac{1}{\epsilon_0} \rho(\mathbf{r}), \quad (2.16)$$

which is Gauss's law in differential form (2.14). To recover the integral form (2.13), we run the previous argument in reverse—integrate over a volume and apply the divergence theorem:

$$\int_V \nabla \cdot \mathbf{E} d\tau = \oint_S \mathbf{E} \cdot d\mathbf{a} = \frac{1}{\epsilon_0} \int_V \rho d\tau = \frac{1}{\epsilon_0} Q_{\text{enc}}.$$

2.2.3 Applications of Gauss's Law

I must interrupt the theoretical development at this point to show you the extraordinary power of Gauss's law, in integral form. When symmetry permits, it affords *by far* the quickest and easiest way of computing electric fields. I'll illustrate the method with a series of examples.

Example 2.2

Find the field outside a uniformly charged solid sphere of radius R and total charge q .

Solution: Draw a spherical surface at radius $r > R$ (Fig. 2.18); this is called a "Gaussian surface" in the trade. Gauss's law says that for this surface (as for any other)

$$\oint_S \mathbf{E} \cdot d\mathbf{a} = \frac{1}{\epsilon_0} Q_{\text{enc}}.$$

and $Q_{\text{enc}} = q$. At first glance this doesn't seem to get us very far, because the quantity we want (\mathbf{E}) is buried inside the surface integral. Luckily, symmetry allows us to extract \mathbf{E} from under the integral sign: \mathbf{E} certainly points radially outward,³ as does $d\mathbf{a}$, so we can drop the dot product,

$$\int_S \mathbf{E} \cdot d\mathbf{a} = \int_S |\mathbf{E}| da,$$

³If you doubt that \mathbf{E} is radial, consider the alternative. Suppose, say, that it points due east, at the "equator." But the orientation of the equator is perfectly arbitrary—nothing is spinning here, so there is no natural "north-south" axis—any argument purporting to show that \mathbf{E} points east could just as well be used to show it points west, or north, or any other direction. The only *unique* direction on a sphere is *radial*.



Figure 2.18

and the *magnitude* of \mathbf{E} is constant over the Gaussian surface, so it comes outside the integral:

$$\int_S |\mathbf{E}| da = |\mathbf{E}| \int_S da = |\mathbf{E}| 4\pi r^2.$$

Thus

$$|\mathbf{E}| 4\pi r^2 = \frac{1}{\epsilon_0} q,$$

or

$$\mathbf{E} = \frac{1}{4\pi\epsilon_0} \frac{q}{r^2} \hat{\mathbf{r}}.$$

Notice a remarkable feature of this result: The field outside the sphere is exactly the *same* as it would have been if all the charge had been concentrated at the center.

Gauss's law is always *true*, but it is not always *useful*. If ρ had not been uniform (or, at any rate, not spherically symmetrical), or if I had chosen some other shape for my Gaussian surface, it would still have been true that the flux of \mathbf{E} is $(1/\epsilon_0)q$, but I would not have been certain that \mathbf{E} was in the same direction as $d\mathbf{a}$ and constant in magnitude over the surface, and without that I could not pull $|\mathbf{E}|$ out of the integral. *Symmetry is crucial* to this application of Gauss's law. As far as I know, there are only three kinds of symmetry that work:

1. *Spherical symmetry.* Make your Gaussian surface a concentric sphere.
2. *Cylindrical symmetry.* Make your Gaussian surface a coaxial cylinder (Fig. 2.19).
3. *Plane symmetry.* Use a Gaussian "pillbox," which straddles the surface (Fig. 2.20).

Although (2) and (3) technically require infinitely long cylinders, and planes extending to infinity in all directions, we shall often use them to get approximate answers for "long" cylinders or "large" plane surfaces, at points far from the edges.

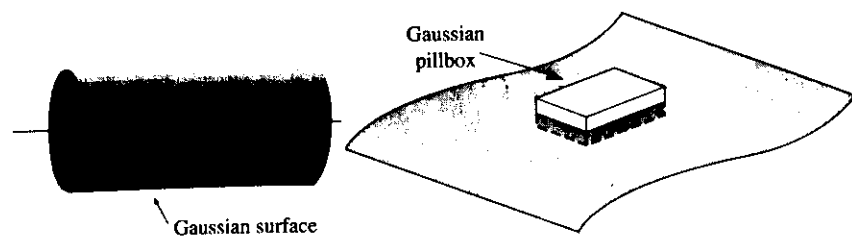

Figure 2.19

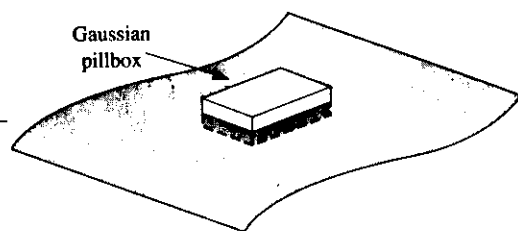

Figure 2.20

Example 2.3

A long cylinder (Fig. 2.21) carries a charge density that is proportional to the distance from the axis: $\rho = ks$, for some constant k . Find the electric field inside this cylinder.

Solution: Draw a Gaussian cylinder of length l and radius s . For this surface, Gauss's law states:

$$\oint_S \mathbf{E} \cdot d\mathbf{a} = \frac{1}{\epsilon_0} Q_{\text{enc.}}$$

The enclosed charge is

$$Q_{\text{enc}} = \int \rho \, d\tau = \int (ks')(s' \, ds' \, d\phi \, dz) = 2\pi kl \int_0^s s'^2 \, ds' = \frac{2}{3}\pi kls^3.$$

(I used the volume element appropriate to cylindrical coordinates, Eq. 1.78, and integrated ϕ from 0 to 2π , dz from 0 to l . I put a prime on the integration variable s' , to distinguish it from the radius s of the Gaussian surface.)

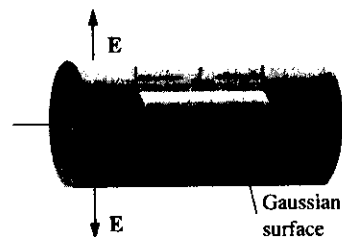

Figure 2.21

2.2. DIVERGENCE AND CURL OF ELECTROSTATIC FIELDS

Now, symmetry dictates that \mathbf{E} must point radially outward, so for the curved portion of the Gaussian cylinder we have:

$$\int \mathbf{E} \cdot d\mathbf{a} = \int |\mathbf{E}| \, da = |\mathbf{E}| \int da = |\mathbf{E}| 2\pi sl,$$

while the two ends contribute nothing (here \mathbf{E} is perpendicular to $d\mathbf{a}$). Thus,

$$|\mathbf{E}| 2\pi sl = \frac{1}{\epsilon_0} \frac{2}{3}\pi kls^3,$$

or, finally,

$$\mathbf{E} = \frac{1}{3\epsilon_0} ks^2 \hat{\mathbf{s}}.$$

Example 2.4

An infinite plane carries a uniform surface charge σ . Find its electric field.

Solution: Draw a "Gaussian pillbox," extending equal distances above and below the plane (Fig. 2.22). Apply Gauss's law to this surface:

$$\oint \mathbf{E} \cdot d\mathbf{a} = \frac{1}{\epsilon_0} Q_{\text{enc.}}$$

In this case, $Q_{\text{enc}} = \sigma A$, where A is the area of the lid of the pillbox. By symmetry, \mathbf{E} points away from the plane (upward for points above, downward for points below). Thus, the top and bottom surfaces yield

$$\int \mathbf{E} \cdot d\mathbf{a} = 2A|\mathbf{E}|,$$

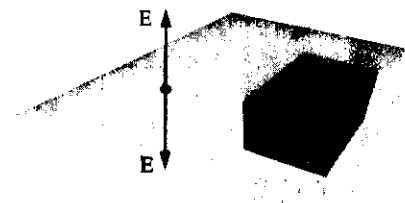

Figure 2.22

whereas the sides contribute nothing. Thus

$$2A |\mathbf{E}| = \frac{1}{\epsilon_0} \sigma A,$$

or

$$\mathbf{E} = \frac{\sigma}{2\epsilon_0} \hat{\mathbf{n}} \quad (2.17)$$

where $\hat{\mathbf{n}}$ is a unit vector pointing away from the surface. In Prob. 2.6, you obtained this same result by a much more laborious method.

It seems surprising, at first, that the field of an infinite plane is *independent of how far away you are*. What about the $1/r^2$ in Coulomb's law? Well, the point is that as you move farther and farther away from the plane, more and more charge comes into your "field of view" (a cone shape extending out from your eye), and this compensates for the diminishing influence of any particular piece. The electric field of a sphere falls off like $1/r^2$; the electric field of an infinite line falls off like $1/r$; and the electric field of an infinite plane does not fall off at all.

Although the direct use of Gauss's law to compute electric fields is limited to cases of spherical, cylindrical, and planar symmetry, we can put together *combinations* of objects possessing such symmetry, even though the arrangement as a whole is not symmetrical. For example, invoking the principle of superposition, we could find the field in the vicinity of two uniformly charged parallel cylinders, or a sphere near an infinite charged plane.

Example 2.5

Two infinite parallel planes carry equal but opposite uniform charge densities $\pm\sigma$ (Fig. 2.23). Find the field in each of the three regions: (i) to the left of both, (ii) between them, (iii) to the right of both.

Solution: The left plate produces a field $(1/2\epsilon_0)\sigma$ which points away from it (Fig. 2.24)—to the left in region (i) and to the right in regions (ii) and (iii). The right plate, being negatively charged, produces a field $(1/2\epsilon_0)\sigma$, which points *toward* it—to the right in regions (i) and (ii) and to the left in region (iii). The two fields cancel in regions (i) and (iii); they conspire in region (ii). **Conclusion:** The field is $(1/\epsilon_0)\sigma$, and points to the right, between the planes; elsewhere it is zero.

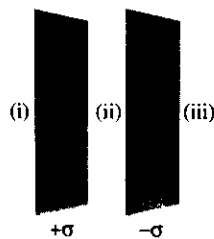

Figure 2.23

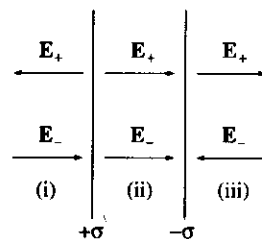

Figure 2.24

Problem 2.11 Use Gauss's law to find the electric field inside and outside a spherical shell of radius R , which carries a uniform surface charge density σ . Compare your answer to Prob. 2.7.

Problem 2.12 Use Gauss's law to find the electric field inside a uniformly charged sphere (charge density ρ). Compare your answer to Prob. 2.8.

Problem 2.13 Find the electric field a distance s from an infinitely long straight wire, which carries a uniform line charge λ . Compare Eq. 2.9.

Problem 2.14 Find the electric field inside a sphere which carries a charge density proportional to the distance from the origin, $\rho = kr$, for some constant k . [Hint: This charge density is *not* uniform, and you must *integrate* to get the enclosed charge.]

Problem 2.15 A hollow spherical shell carries charge density

$$\rho = \frac{k}{r^2}$$

in the region $a \leq r \leq b$ (Fig. 2.25). Find the electric field in the three regions: (i) $r < a$, (ii) $a < r < b$, (iii) $r > b$. Plot $|\mathbf{E}|$ as a function of r .

Problem 2.16 A long coaxial cable (Fig. 2.26) carries a uniform *volume* charge density ρ on the inner cylinder (radius a), and a uniform *surface* charge density on the outer cylindrical shell (radius b). This surface charge is negative and of just the right magnitude so that the cable as a whole is electrically neutral. Find the electric field in each of the three regions: (i) inside the inner cylinder ($s < a$), (ii) between the cylinders ($a < s < b$), (iii) outside the cable ($s > b$). Plot $|\mathbf{E}|$ as a function of s .

Problem 2.17 An infinite plane slab, of thickness $2d$, carries a uniform volume charge density ρ (Fig. 2.27). Find the electric field, as a function of y , where $y = 0$ at the center. Plot E versus y , calling E positive when it points in the $+y$ direction and negative when it points in the $-y$ direction.

- Problem 2.18** Two spheres, each of radius R and carrying uniform charge densities $+\rho$ and $-\rho$, respectively, are placed so that they partially overlap (Fig. 2.28). Call the vector from the positive center to the negative center \mathbf{d} . Show that the field in the region of overlap is constant, and find its value. [Hint: Use the answer to Prob. 2.12.]

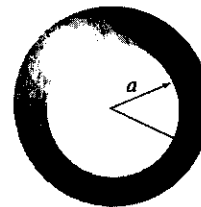

Figure 2.25



Figure 2.26

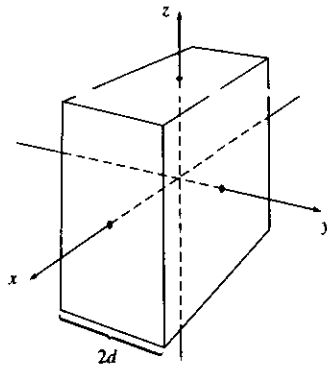

Figure 2.27

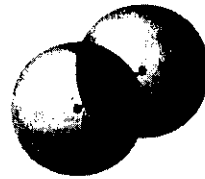

Figure 2.28

2.2.4 The Curl of \mathbf{E}

I'll calculate the curl of \mathbf{E} , as I did the divergence in Sect. 2.2.1, by studying first the simplest possible configuration: a point charge at the origin. In this case

$$\mathbf{E} = \frac{1}{4\pi\epsilon_0} \frac{q}{r^2} \hat{\mathbf{r}}.$$

Now, a glance at Fig. 2.12 should convince you that the curl of this field has to be zero, but I suppose we ought to come up with something a little more rigorous than that. What if we calculate the line integral of this field from some point \mathbf{a} to some other point \mathbf{b} (Fig. 2.29):

$$\int_{\mathbf{a}}^{\mathbf{b}} \mathbf{E} \cdot d\mathbf{l}.$$

In spherical coordinates, $d\mathbf{l} = dr \hat{\mathbf{r}} + r d\theta \hat{\boldsymbol{\theta}} + r \sin\theta d\phi \hat{\boldsymbol{\phi}}$, so

$$\mathbf{E} \cdot d\mathbf{l} = \frac{1}{4\pi\epsilon_0} \frac{q}{r^2} dr.$$

Therefore,

$$\int_{\mathbf{a}}^{\mathbf{b}} \mathbf{E} \cdot d\mathbf{l} = \frac{1}{4\pi\epsilon_0} \int_{r_a}^{r_b} \frac{q}{r^2} dr = \frac{-1}{4\pi\epsilon_0} \frac{q}{r} \Big|_{r_a}^{r_b} = \frac{1}{4\pi\epsilon_0} \left(\frac{q}{r_a} - \frac{q}{r_b} \right), \quad (2.18)$$

where r_a is the distance from the origin to the point \mathbf{a} and r_b is the distance to \mathbf{b} . The integral around a *closed* path is evidently zero (for then $r_a = r_b$):

$$\oint \mathbf{E} \cdot d\mathbf{l} = 0, \quad (2.19)$$

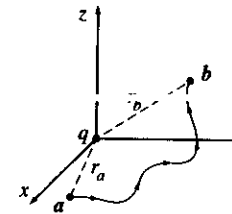

Figure 2.29

and hence, applying Stokes' theorem,

$$\boxed{\nabla \times \mathbf{E} = 0.} \quad (2.20)$$

Now, I proved Eqs. 2.19 and 2.20 only for the field of a single point charge at the *origin*, but these results make no reference to what is, after all, a perfectly arbitrary choice of coordinates; they also hold no matter *where* the charge is located. Moreover, if we have many charges, the principle of superposition states that the total field is a vector sum of their individual fields:

$$\mathbf{E} = \mathbf{E}_1 + \mathbf{E}_2 + \dots,$$

so

$$\nabla \times \mathbf{E} = \nabla \times (\mathbf{E}_1 + \mathbf{E}_2 + \dots) = (\nabla \times \mathbf{E}_1) + (\nabla \times \mathbf{E}_2) + \dots = 0.$$

Thus, Eqs. 2.19 and 2.20 hold for *any static charge distribution whatever*.

Problem 2.19 Calculate $\nabla \times \mathbf{E}$ directly from Eq. 2.8, by the method of Sect. 2.2.2. Refer to Prob. 1.62 if you get stuck.

2.3 Electric Potential

2.3.1 Introduction to Potential

The electric field \mathbf{E} is not just *any* old vector function; it is a very special *kind* of vector function, one whose curl is always zero. $\mathbf{E} = y\hat{\mathbf{x}}$, for example, could not possibly be an electrostatic field; *no* set of charges, regardless of their sizes and positions, could ever produce such a field. In this section we're going to exploit this special property of electric fields to reduce a vector problem (finding \mathbf{E}) down to a much simpler scalar problem. The first theorem in Sect. 1.6.2 asserts that any vector whose curl is zero is equal to the gradient of some scalar. What I'm going to do now amounts to a proof of that claim, in the context of electrostatics.

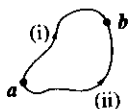

Figure 2.30

Because $\nabla \times \mathbf{E} = 0$, the line integral of \mathbf{E} around any closed loop is zero (that follows from Stokes' theorem). Because $\oint \mathbf{E} \cdot d\mathbf{l} = 0$, the line integral of \mathbf{E} from point \mathbf{a} to point \mathbf{b} is the same for all paths (otherwise you could go *out* along path (i) and return along path (ii)—Fig. 2.30—and obtain $\oint \mathbf{E} \cdot d\mathbf{l} \neq 0$). Because the line integral is independent of path, we can define a function⁴

$$V(\mathbf{r}) \equiv - \int_{\mathcal{O}}^{\mathbf{r}} \mathbf{E} \cdot d\mathbf{l}. \quad (2.21)$$

Here \mathcal{O} is some standard reference point on which we have agreed beforehand; V then depends only on the point \mathbf{r} . It is called the **electric potential**. Evidently, the potential *difference* between two points \mathbf{a} and \mathbf{b} is

$$\begin{aligned} V(\mathbf{b}) - V(\mathbf{a}) &= - \int_{\mathcal{O}}^{\mathbf{b}} \mathbf{E} \cdot d\mathbf{l} + \int_{\mathcal{O}}^{\mathbf{a}} \mathbf{E} \cdot d\mathbf{l} \\ &= - \int_{\mathcal{O}}^{\mathbf{b}} \mathbf{E} \cdot d\mathbf{l} - \int_{\mathbf{a}}^{\mathcal{O}} \mathbf{E} \cdot d\mathbf{l} = - \int_{\mathbf{a}}^{\mathbf{b}} \mathbf{E} \cdot d\mathbf{l}. \end{aligned} \quad (2.22)$$

Now, the fundamental theorem for gradients states that

$$V(\mathbf{b}) - V(\mathbf{a}) = \int_{\mathbf{a}}^{\mathbf{b}} (\nabla V) \cdot d\mathbf{l},$$

so

$$\int_{\mathbf{a}}^{\mathbf{b}} (\nabla V) \cdot d\mathbf{l} = - \int_{\mathbf{a}}^{\mathbf{b}} \mathbf{E} \cdot d\mathbf{l}.$$

Since, finally, this is true for *any* points \mathbf{a} and \mathbf{b} , the integrands must be equal:

$$\boxed{\mathbf{E} = -\nabla V}. \quad (2.23)$$

Equation 2.23 is the differential version of Eq. 2.21; it says that the electric field is the gradient of a scalar potential, which is what we set out to prove.

⁴To avoid any possible ambiguity I should perhaps put a prime on the integration variable:

$$V(\mathbf{r}) = - \int_{\mathcal{O}}^{\mathbf{r}} \mathbf{E}(\mathbf{r}') \cdot d\mathbf{l}'.$$

But this makes for cumbersome notation, and I prefer whenever possible to reserve the primes for source points. However, when (as in Ex. 2.6) we calculate such integrals explicitly, I shall put in the primes.

Notice the subtle but crucial role played by path independence (or, equivalently, the fact that $\nabla \times \mathbf{E} = 0$) in this argument. If the line integral of \mathbf{E} depended on the path taken, then the “definition” of V , Eq. 2.21, would be nonsense. It simply would not define a function, since changing the path would alter the value of $V(\mathbf{r})$. By the way, don't let the minus sign in Eq. 2.23 distract you; it carries over from 2.21 and is largely a matter of convention.

Problem 2.20 One of these is an impossible electrostatic field. Which one?

(a) $\mathbf{E} = k[xy \hat{\mathbf{x}} + 2yz \hat{\mathbf{y}} + 3xz \hat{\mathbf{z}}];$

(b) $\mathbf{E} = k[y^2 \hat{\mathbf{x}} + (2xy + z^2) \hat{\mathbf{y}} + 2yz \hat{\mathbf{z}}].$

Here k is a constant with the appropriate units. For the *possible* one, find the potential, using the *origin* as your reference point. Check your answer by computing ∇V . [Hint: You must select a specific path to integrate along. It doesn't matter *what* path you choose, since the answer is path-independent, but you simply cannot integrate unless you have a particular path in mind.]

2.3.2 Comments on Potential

(i) **The name.** The word “potential” is a hideous misnomer because it inevitably reminds you of potential *energy*. This is particularly confusing, because there *is* a connection between “potential” and “potential energy,” as you will see in Sect. 2.4. I'm sorry that it is impossible to escape this word. The best I can do is to insist once and for all that “potential” and “potential energy” are completely different terms and should, by all rights, have different names. Incidentally, a surface over which the potential is constant is called an **equipotential**.

(ii) **Advantage of the potential formulation.** If you know V , you can easily get \mathbf{E} —just take the gradient: $\mathbf{E} = -\nabla V$. This is quite extraordinary when you stop to think about it, for \mathbf{E} is a *vector* quantity (three components), but V is a *scalar* (one component). How can *one* function possibly contain all the information that *three* independent functions carry? The answer is that the three components of \mathbf{E} are not really as independent as they look; in fact, they are explicitly interrelated by the very condition we started with, $\nabla \times \mathbf{E} = 0$. In terms of components,

$$\frac{\partial E_x}{\partial y} = \frac{\partial E_y}{\partial x}, \quad \frac{\partial E_z}{\partial y} = \frac{\partial E_y}{\partial z}, \quad \frac{\partial E_x}{\partial z} = \frac{\partial E_z}{\partial x}.$$

This brings us back to my observation at the beginning of Sect. 2.3.1: \mathbf{E} is a *very special kind of vector*. What the potential formulation does is to exploit this feature to maximum advantage, reducing a vector problem down to a scalar one, in which there is no need to fuss with components.

(iii) **The reference point \mathcal{O} .** There is an essential ambiguity in the definition of potential, since the choice of reference point \mathcal{O} was arbitrary. Changing reference points amounts to adding a constant K to the potential:

$$V'(\mathbf{r}) = - \int_{\mathcal{O}'}^{\mathbf{r}} \mathbf{E} \cdot d\mathbf{l} = - \int_{\mathcal{O}}^{\mathcal{O}'} \mathbf{E} \cdot d\mathbf{l} - \int_{\mathcal{O}}^{\mathbf{r}} \mathbf{E} \cdot d\mathbf{l} = K + V(\mathbf{r}),$$

where K is the line integral of \mathbf{E} from the old reference point \mathcal{O} to the new one \mathcal{O}' . Of course, adding a constant to V will not affect the potential *difference* between two points:

$$V'(\mathbf{b}) - V'(\mathbf{a}) = V(\mathbf{b}) - V(\mathbf{a}),$$

since the K 's cancel out. (Actually, it was already clear from Eq. 2.22 that the potential difference is independent of \mathcal{O} , because it can be written as the line integral of \mathbf{E} from \mathbf{a} to \mathbf{b} , with no reference to \mathcal{O} .) Nor does the ambiguity affect the gradient of V :

$$\nabla V' = \nabla V,$$

since the derivative of a constant is zero. That's why all such V 's, differing only in their choice of reference point, correspond to the same field \mathbf{E} .

Evidently potential as such carries no real physical significance, for at any given point we can adjust its value at will by a suitable relocation of \mathcal{O} . In this sense it is rather like altitude: If I ask you how high Denver is, you will probably tell me its height above sea level, because that is a convenient and traditional reference point. But we could as well agree to measure altitude above Washington D.C., or Greenwich, or wherever. That would add (or, rather, subtract) a fixed amount from all our sea-level readings, but it wouldn't change anything about the real world. The only quantity of intrinsic interest is the *difference* in altitude between two points, and *that* is the same *whatever* your reference level.

Having said this, however, there is a "natural" spot to use for \mathcal{O} in electrostatics—analogueous to sea level for altitude—and that is a point infinitely far from the charge. Ordinarily, then, we "set the zero of potential at infinity." (Since $V(\mathcal{O}) = 0$, choosing a reference point is equivalent to selecting a place where V is to be zero.) But I must warn you that there is one special circumstance in which this convention fails: when the charge distribution itself extends to infinity. The symptom of trouble, in such cases, is that the potential blows up. For instance, the field of a uniformly charged plane is $(\sigma/2\epsilon_0)\hat{n}$, as we found in Ex. 2.4; if we naively put $\mathcal{O} = \infty$, then the potential at height z above the plane becomes

$$V(z) = - \int_{\infty}^z \frac{1}{2\epsilon_0} \sigma dz = - \frac{1}{2\epsilon_0} \sigma (z - \infty).$$

The remedy is simply to choose some other reference point (in this problem you might use the origin). Notice that the difficulty occurs only in textbook problems; in "real life" there is no such thing as a charge distribution that goes on forever, and we can *always* use infinity as our reference point.

(iv) **Potential obeys the superposition principle.** The original superposition principle of electrodynamics pertains to the force on a test charge Q . It says that the total force on Q is the vector sum of the forces attributable to the source charges individually:

$$\mathbf{F} = \mathbf{F}_1 + \mathbf{F}_2 + \dots$$

Dividing through by Q , we find that the electric field, too, obeys the superposition principle:

$$\mathbf{E} = \mathbf{E}_1 + \mathbf{E}_2 + \dots$$

Integrating from the common reference point to \mathbf{r} , it follows that the potential also satisfies such a principle:

$$V = V_1 + V_2 + \dots$$

That is, the potential at any given point is the sum of the potentials due to all the source charges separately. Only this time it is an *ordinary* sum, not a *vector* sum, which makes it a lot easier to work with.

(v) **Units of Potential.** In our units, force is measured in newtons and charge in coulombs, so electric fields are in newtons per coulomb. Accordingly, potential is measured in newton-meters per coulomb or joules per coulomb. A joule per coulomb is called a **volt**.

Example 2.6

Find the potential inside and outside a spherical shell of radius R (Fig. 2.31), which carries a uniform surface charge. Set the reference point at infinity.

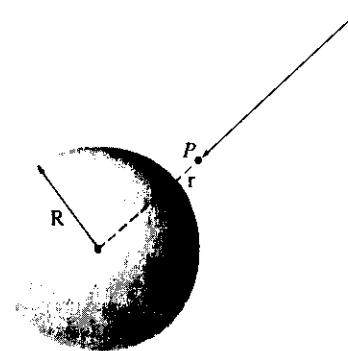

Figure 2.31

Solution: From Gauss's law, the field outside is

$$\mathbf{E} = \frac{1}{4\pi\epsilon_0} \frac{q}{r^2} \hat{\mathbf{r}},$$

where q is the total charge on the sphere. The field inside is zero. For points outside the sphere ($r > R$),

$$V(r) = - \int_{\infty}^r \mathbf{E} \cdot d\mathbf{l} = \frac{-1}{4\pi\epsilon_0} \int_{\infty}^r \frac{q}{r'^2} dr' = \frac{1}{4\pi\epsilon_0} \frac{q}{r'} \Big|_{\infty}^r = \frac{1}{4\pi\epsilon_0} \frac{q}{r}.$$

To find the potential inside the sphere ($r < R$), we must break the integral into two sections, using in each region the field that prevails there:

$$V(r) = \frac{-1}{4\pi\epsilon_0} \int_{\infty}^R \frac{q}{r'^2} dr' - \int_R^r (0) dr' = \frac{1}{4\pi\epsilon_0} \frac{q}{r'} \Big|_{\infty}^R + 0 = \frac{1}{4\pi\epsilon_0} \frac{q}{R}.$$

Notice that the potential is *not* zero inside the shell, even though the field is. V is a *constant* in this region, to be sure, so that $\nabla V = 0$ —that's what matters. In problems of this type you must always *work your way in from the reference point*; that's where the potential is "nailed down." It is tempting to suppose that you could figure out the potential inside the sphere on the basis of the field there alone, but this is false: The potential inside the sphere is sensitive to what's going on outside the sphere as well. If I placed a second uniformly charged shell out at radius $R' > R$, the potential inside R would change, even though the field would still be zero. Gauss's law guarantees that charge exterior to a given point (that is, at larger r) produces no net field at that point, provided it is spherically or cylindrically symmetric; but there is no such rule for *potential*, when infinity is used as the reference point.

Problem 2.21 Find the potential inside and outside a uniformly charged solid sphere whose radius is R and whose total charge is q . Use infinity as your reference point. Compute the gradient of V in each region, and check that it yields the correct field. Sketch $V(r)$.

Problem 2.22 Find the potential a distance s from an infinitely long straight wire that carries a uniform line charge λ . Compute the gradient of your potential, and check that it yields the correct field.

Problem 2.23 For the charge configuration of Prob. 2.15, find the potential at the center, using infinity as your reference point.

Problem 2.24 For the configuration of Prob. 2.16, find the potential difference between a point on the axis and a point on the outer cylinder. Note that it is not necessary to commit yourself to a particular reference point if you use Eq. 2.22.

2.3.3 Poisson's Equation and Laplace's Equation

We found in Sect. 2.3.1 that the electric field can be written as the gradient of a scalar potential.

$$\mathbf{E} = -\nabla V.$$

The question arises: What do the fundamental equations for \mathbf{E} ,

$$\nabla \cdot \mathbf{E} = \frac{\rho}{\epsilon_0} \quad \text{and} \quad \nabla \times \mathbf{E} = 0,$$

look like, in terms of V ? Well, $\nabla \cdot \mathbf{E} = \nabla \cdot (-\nabla V) = -\nabla^2 V$, so, apart from that persisting minus sign, the divergence of \mathbf{E} is the Laplacian of V . Gauss's law then says that

$$\boxed{\nabla^2 V = -\frac{\rho}{\epsilon_0}} \quad (2.24)$$

This is known as **Poisson's equation**. In regions where there is no charge, so that $\rho = 0$, Poisson's equation reduces to **Laplace's equation**,

$$\nabla^2 V = 0. \quad (2.25)$$

We'll explore these equations more fully in Chapter 3.

So much for Gauss's law. What about the curl law? This says that

$$\nabla \times \mathbf{E} = \nabla \times (-\nabla V)$$

must equal zero. But that's no condition on V —curl of gradient is *always* zero. Of course, we *used* the curl law to show that \mathbf{E} could be expressed as the gradient of a scalar, so it's not really surprising that this works out: $\nabla \times \mathbf{E} = 0$ *permits* $\mathbf{E} = -\nabla V$; in return, $\mathbf{E} = -\nabla V$ *guarantees* $\nabla \times \mathbf{E} = 0$. It takes only *one* differential equation (Poisson's) to determine V , because V is a scalar; for \mathbf{E} we needed *two*, the divergence and the curl.

2.3.4 The Potential of a Localized Charge Distribution

I defined V in terms of \mathbf{E} (Eq. 2.21). Ordinarily, though, it's \mathbf{E} that we're looking for (if we already knew \mathbf{E} there wouldn't be much point in calculating V). The idea is that it might be easier to get V first, and then calculate \mathbf{E} by taking the gradient. Typically, then, we know where the charge is (that is, we know ρ), and we want to find V . Now, Poisson's equation relates V and ρ , but unfortunately it's "the wrong way around": it would give us ρ , if we knew V , whereas we want V , knowing ρ . What we must do, then, is "invert" Poisson's equation. That's the program for this section, although I shall do it by roundabout means, beginning, as always, with a point charge at the origin.



Figure 2.32

Setting the reference point at infinity, the potential of a point charge q at the origin is

$$V(r) = \frac{-1}{4\pi\epsilon_0} \int_{\infty}^r \frac{q}{r'^2} dr' = \frac{1}{4\pi\epsilon_0} \frac{q}{r'} \Big|_{\infty}^r = \frac{1}{4\pi\epsilon_0} \frac{q}{r}.$$

(You see here the special virtue of using infinity for the reference point: it kills the lower limit on the integral.) Notice the sign of V ; presumably the conventional minus sign in the definition of V (Eq. 2.21) was chosen precisely in order to *make* the potential of a positive charge come out positive. It is useful to remember that regions of positive charge are potential “hills,” regions of negative charge are potential “valleys,” and the electric field points “downhill,” from plus toward minus.

In general, the potential of a point charge q is

$$V(\mathbf{r}) = \frac{1}{4\pi\epsilon_0} \frac{q}{z}, \quad (2.26)$$

where z , as always, is the distance from the charge to \mathbf{r} (Fig. 2.32). Invoking the superposition principle, then, the potential of a collection of charges is

$$V(\mathbf{r}) = \frac{1}{4\pi\epsilon_0} \sum_{i=1}^n \frac{q_i}{z_i}, \quad (2.27)$$

or, for a continuous distribution,

$$V(\mathbf{r}) = \frac{1}{4\pi\epsilon_0} \int \frac{1}{z} dq. \quad (2.28)$$

In particular, for a volume charge, it's

$$V(\mathbf{r}) = \frac{1}{4\pi\epsilon_0} \int \frac{\rho(\mathbf{r}')}{z} d\tau'. \quad (2.29)$$

This is the equation we were looking for, telling us how to compute V when we know ρ ; it is, if you like, the “solution” to Poisson’s equation, for a localized charge distribution.⁵ I

⁵Equation 2.29 is an example of the Helmholtz theorem (Appendix B), in the context of electrostatics, where the curl of \mathbf{E} is zero and its divergence is ρ/ϵ_0 .

invite you to compare Eq. 2.29 with the corresponding formula for the electric field in terms of ρ (Eq. 2.8):

$$\mathbf{E}(\mathbf{r}) = \frac{1}{4\pi\epsilon_0} \int \frac{\rho(\mathbf{r}')}{z^2} \hat{\mathbf{z}} d\tau'.$$

The main point to notice is that the pesky unit vector $\hat{\mathbf{z}}$ is now missing, so there is no need to worry about components. Incidentally, the potentials of line and surface charges are

$$\frac{1}{4\pi\epsilon_0} \int \frac{\lambda(\mathbf{r}')}{z} dl' \quad \text{and} \quad \frac{1}{4\pi\epsilon_0} \int \frac{\sigma(\mathbf{r}')}{z} da'. \quad (2.30)$$

I should warn you that everything in this section is predicated on the assumption that the reference point is at infinity. This is hardly apparent in Eq. 2.29, but remember that we got that equation from the potential of a point charge at the origin, $(1/4\pi\epsilon_0)(q/r)$, which is valid only when $\mathcal{O} = \infty$. If you try to apply these formulas to one of those artificial problems in which the charge itself extends to infinity, the integral will diverge.

Example 2.7

Find the potential of a uniformly charged spherical shell of radius R (Fig. 2.33).

Solution: This is the same problem we solved in Ex. 2.6, but this time we shall do it using Eq. 2.30:

$$V(\mathbf{r}) = \frac{1}{4\pi\epsilon_0} \int \frac{\sigma}{z} da'.$$

Let’s set the point \mathbf{r} on the z axis and use the law of cosines to express z in terms of the polar angle θ :

$$z^2 = R^2 + z^2 - 2Rz \cos \theta'.$$

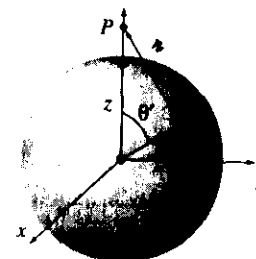

Figure 2.33

An element of surface area on this sphere is $R^2 \sin \theta' d\theta' d\phi'$, so

$$\begin{aligned} 4\pi\epsilon_0 V(z) &= \sigma \int \frac{R^2 \sin \theta' d\theta' d\phi'}{\sqrt{R^2 + z^2 - 2Rz \cos \theta'}} \\ &= 2\pi R^2 \sigma \int_0^\pi \frac{\sin \theta'}{\sqrt{R^2 + z^2 - 2Rz \cos \theta'}} d\theta' \\ &= 2\pi R^2 \sigma \left(\frac{1}{Rz} \sqrt{R^2 + z^2 - 2Rz \cos \theta'} \right) \Big|_0^\pi \\ &= \frac{2\pi R\sigma}{z} \left(\sqrt{R^2 + z^2 + 2Rz} - \sqrt{R^2 + z^2 - 2Rz} \right) \\ &= \frac{2\pi R\sigma}{z} \left[\sqrt{(R+z)^2} - \sqrt{(R-z)^2} \right]. \end{aligned}$$

At this stage we must be very careful to take the *positive* root. For points *outside* the sphere, z is greater than R , and hence $\sqrt{(R-z)^2} = z-R$; for points *inside* the sphere, $\sqrt{(R-z)^2} = R-z$. Thus,

$$\begin{aligned} V(z) &= \frac{R\sigma}{2\epsilon_0 z} [(R+z) - (z-R)] = \frac{R^2\sigma}{\epsilon_0 z}, & \text{outside;} \\ V(z) &= \frac{R\sigma}{2\epsilon_0 z} [(R+z) - (R-z)] = \frac{R\sigma}{\epsilon_0}, & \text{inside.} \end{aligned}$$

In terms of the total charge on the shell, $q = 4\pi R^2\sigma$, $V(z) = (1/4\pi\epsilon_0)(q/z)$ (or, in general, $V(r) = (1/4\pi\epsilon_0)(q/r)$) for points outside the sphere, and $(1/4\pi\epsilon_0)(q/R)$ for points inside.

Of course, in this particular case, it was easier to get V by using 2.21 than 2.30, because Gauss's law gave us \mathbf{E} with so little effort. But if you compare Ex. 2.7 with Prob. 2.7, you will appreciate the power of the potential formulation.

Problem 2.25 Using Eqs. 2.27 and 2.30, find the potential at a distance z above the center of the charge distributions in Fig. 2.34. In each case, compute $\mathbf{E} = -\nabla V$, and compare your answers with Prob. 2.2a, Ex. 2.1, and Prob. 2.6, respectively. Suppose that we changed the right-hand charge in Fig. 2.34a to $-q$; what then is the potential at P ? What field does that suggest? Compare your answer to Prob. 2.2b, and explain carefully any discrepancy.

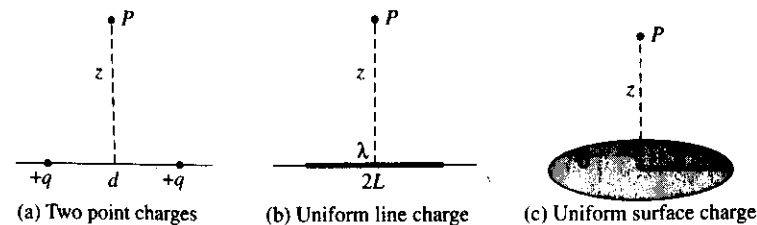

Figure 2.34

Problem 2.26 A conical surface (an empty ice-cream cone) carries a uniform surface charge σ . The height of the cone is h , as is the radius of the top. Find the potential difference between points **a** (the vertex) and **b** (the center of the top).

Problem 2.27 Find the potential on the axis of a uniformly charged solid cylinder, a distance z from the center. The length of the cylinder is L , its radius is R , and the charge density is ρ . Use your result to calculate the electric field at this point. (Assume that $z > L/2$.)

Problem 2.28 Use Eq. 2.29 to calculate the potential inside a uniformly charged solid sphere of radius R and total charge q . Compare your answer to Prob. 2.21.

Problem 2.29 Check that Eq. 2.29 satisfies Poisson's equation, by applying the Laplacian and using Eq. 1.102.

2.3.5 Summary; Electrostatic Boundary Conditions

In the typical electrostatic problem you are given a source charge distribution ρ , and you want to find the electric field \mathbf{E} it produces. Unless the symmetry of the problem admits a solution by Gauss's law, it is generally to your advantage to calculate the potential first, as an intermediate step. These, then, are the three fundamental quantities of electrostatics: ρ , \mathbf{E} , and V . We have, in the course of our discussion, derived all six formulas interrelating them. These equations are neatly summarized in Fig. 2.35. We began with just two experimental observations: (1) the principle of superposition—a broad general rule applying to *all* electromagnetic forces, and (2) Coulomb's law—the fundamental law of electrostatics. From these, all else followed.

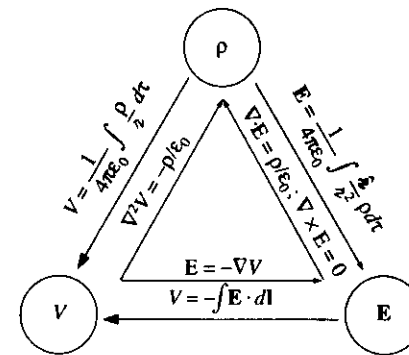

Figure 2.35

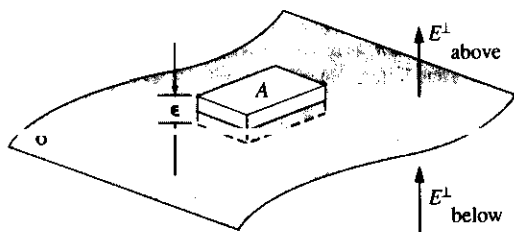

Figure 2.36

You may have noticed, in studying Exs. 2.4 and 2.5, or working problems such as 2.7, 2.11, and 2.16, that the electric field always undergoes a discontinuity when you cross a surface charge σ . In fact, it is a simple matter to find the *amount* by which \mathbf{E} changes at such a boundary. Suppose we draw a wafer-thin Gaussian pillbox, extending just barely over the edge in each direction (Fig. 2.36). Gauss's law states that

$$\oint_S \mathbf{E} \cdot d\mathbf{a} = \frac{1}{\epsilon_0} Q_{\text{enc}} = \frac{1}{\epsilon_0} \sigma A,$$

where A is the area of the pillbox lid. (If σ varies from point to point or the surface is curved, we must pick A to be extremely small.) Now, the *sides* of the pillbox contribute nothing to the flux, in the limit as the thickness ϵ goes to zero, so we are left with

$$E_{\text{above}}^{\perp} - E_{\text{below}}^{\perp} = \frac{1}{\epsilon_0} \sigma, \quad (2.31)$$

where E_{above}^{\perp} denotes the component of \mathbf{E} that is perpendicular to the surface immediately above, and E_{below}^{\perp} is the same, only just below the surface. For consistency, we let "upward" be the positive direction for both. *Conclusion: The normal component of \mathbf{E} is discontinuous by an amount σ/ϵ_0 at any boundary.* In particular, where there is no surface charge, E^{\perp} is continuous, as for instance at the surface of a uniformly charged solid sphere.

The *tangential* component of \mathbf{E} , by contrast, is *always* continuous. For if we apply Eq. 2.19,

$$\oint \mathbf{E} \cdot d\mathbf{l} = 0,$$

to the thin rectangular loop of Fig. 2.37, the ends give nothing (as $\epsilon \rightarrow 0$), and the sides give $(E_{\text{above}}^{\parallel} l - E_{\text{below}}^{\parallel} l)$, so

$$\mathbf{E}_{\text{above}}^{\parallel} = \mathbf{E}_{\text{below}}^{\parallel}, \quad (2.32)$$

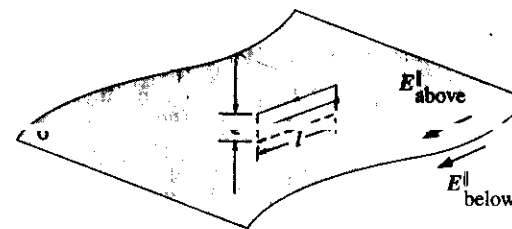

Figure 2.37

where \mathbf{E}^{\parallel} stands for the components of \mathbf{E} *parallel* to the surface. The boundary conditions on \mathbf{E} (Eqs. 2.31 and 2.32) can be combined into a single formula:

$$\mathbf{E}_{\text{above}} - \mathbf{E}_{\text{below}} = \frac{\sigma}{\epsilon_0} \hat{\mathbf{n}}, \quad (2.33)$$

where $\hat{\mathbf{n}}$ is a unit vector perpendicular to the surface, pointing from "below" to "above."⁶ The potential, meanwhile, is continuous across any boundary (Fig. 2.38), since

$$V_{\text{above}} - V_{\text{below}} = - \int_a^b \mathbf{E} \cdot d\mathbf{l};$$

as the path length shrinks to zero, so too does the integral:

$$V_{\text{above}} = V_{\text{below}}. \quad (2.34)$$

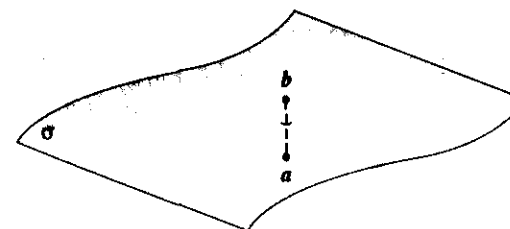

Figure 2.38

⁶Notice that it doesn't matter which side you call "above" and which "below," since reversal would switch the direction of $\hat{\mathbf{n}}$. Incidentally, if you're only interested in the field *due to the* (essentially flat) *local patch of surface charge itself*, the answer is $(\sigma/2\epsilon_0)\hat{\mathbf{n}}$ immediately above the surface, and $-(\sigma/2\epsilon_0)\hat{\mathbf{n}}$ immediately below. This follows from Ex. 2.4, for if you are close enough to the patch it "looks" like an infinite plane. Evidently the entire discontinuity in \mathbf{E} is attributable to this local patch of charge.

However, the *gradient* of V inherits the discontinuity in \mathbf{E} ; since $\mathbf{E} = -\nabla V$, Eq. 2.33 implies that

$$\nabla V_{\text{above}} - \nabla V_{\text{below}} = -\frac{1}{\epsilon_0} \sigma \hat{\mathbf{n}}, \quad (2.35)$$

or, more conveniently,

$$\frac{\partial V_{\text{above}}}{\partial n} - \frac{\partial V_{\text{below}}}{\partial n} = -\frac{1}{\epsilon_0} \sigma, \quad (2.36)$$

where

$$\frac{\partial V}{\partial n} = \nabla V \cdot \hat{\mathbf{n}} \quad (2.37)$$

denotes the **normal derivative** of V (that is, the rate of change in the direction perpendicular to the surface).

Please note that these boundary conditions relate the fields and potentials *just above* and *just below* the surface. For example, the derivatives in Eq. 2.36 are the *limiting* values as we approach the surface from either side.

Problem 2.30

- (a) Check that the results of Exs. 2.4 and 2.5, and Prob. 2.11, are consistent with Eq. 2.33.
 (b) Use Gauss's law to find the field inside and outside a long hollow cylindrical tube, which carries a uniform surface charge σ . Check that your result is consistent with Eq. 2.33.
 (c) Check that the result of Ex. 2.7 is consistent with boundary conditions 2.34 and 2.36.

2.4 Work and Energy in Electrostatics

2.4.1 The Work Done to Move a Charge

Suppose you have a stationary configuration of source charges, and you want to move a test charge Q from point \mathbf{a} to point \mathbf{b} (Fig. 2.39). *Question:* How much work will you have to do? At any point along the path, the electric force on Q is $\mathbf{F} = Q\mathbf{E}$; the force *you* must exert, in opposition to this electrical force, is $-\mathbf{F}$. (If the sign bothers you, think about lifting a brick: Gravity exerts a force mg downward, but *you* exert a force mg upward. Of course, you *could* apply an even greater force—then the brick would accelerate, and part



Figure 2.39

2.4. WORK AND ENERGY IN ELECTROSTATICS

of your effort would be "wasted" generating kinetic energy. What we're interested in here is the *minimum* force you must exert to do the job.) The work is therefore

$$W = \int_{\mathbf{a}}^{\mathbf{b}} \mathbf{F} \cdot d\mathbf{s} = Q \int_{\mathbf{a}}^{\mathbf{b}} \mathbf{E} \cdot d\mathbf{s} = Q[V(\mathbf{a}) - V(\mathbf{b})].$$

Notice that the answer is independent of the path you take from \mathbf{a} to \mathbf{b} ; in mechanics, then, we would call the electrostatic force "conservative." Dividing through by Q , we have

$$V(\mathbf{b}) - V(\mathbf{a}) = \frac{W}{Q}. \quad (2.38)$$

In words, the *potential difference between points \mathbf{a} and \mathbf{b}* is equal to the *work per unit charge required to carry a particle from \mathbf{a} to \mathbf{b}* . In particular, if you want to bring the charge Q in from far away and stick it at point \mathbf{r} , the work you must do is

$$W = Q[V(\mathbf{r}) - V(\infty)],$$

so, if you have set the reference point at infinity,

$$W = QV(\mathbf{r}). \quad (2.39)$$

In this sense *potential* is *potential energy* (the work it takes to create the system) *per unit charge* (just as the *field* is the *force per unit charge*).

2.4.2 The Energy of a Point Charge Distribution

How much work would it take to assemble an entire *collection* of point charges? Imagine bringing in the charges, one by one, from far away (Fig. 2.40). The first charge, q_1 , takes *no* work, since there is no field yet to fight against. Now bring in q_2 . According to Eq. 2.39, this will cost you $q_2 V_1(\mathbf{r}_2)$, where V_1 is the potential due to q_1 , and \mathbf{r}_2 is the place we're putting q_2 :

$$W_2 = \frac{1}{4\pi\epsilon_0} q_2 \left(\frac{q_1}{r_{12}} \right)$$

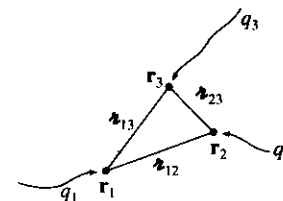

Figure 2.40

(z_{12} is the distance between q_1 and q_2 once they are in position). Now bring in q_3 ; this requires work $q_3 V_{1,2}(\mathbf{r}_3)$, where $V_{1,2}$ is the potential due to charges q_1 and q_2 , namely, $(1/4\pi\epsilon_0)(q_1/z_{13} + q_2/z_{23})$. Thus

$$W_3 = \frac{1}{4\pi\epsilon_0} q_3 \left(\frac{q_1}{z_{13}} + \frac{q_2}{z_{23}} \right).$$

Similarly, the extra work to bring in q_4 will be

$$W_4 = \frac{1}{4\pi\epsilon_0} q_4 \left(\frac{q_1}{z_{14}} + \frac{q_2}{z_{24}} + \frac{q_3}{z_{34}} \right).$$

The *total* work necessary to assemble the first four charges, then, is

$$W = \frac{1}{4\pi\epsilon_0} \left(\frac{q_1 q_2}{z_{12}} + \frac{q_1 q_3}{z_{13}} + \frac{q_1 q_4}{z_{14}} + \frac{q_2 q_3}{z_{23}} + \frac{q_2 q_4}{z_{24}} + \frac{q_3 q_4}{z_{34}} \right).$$

You see the general rule: Take the product of each pair of charges, divide by their separation distance, and add it all up:

$$W = \frac{1}{4\pi\epsilon_0} \sum_{i=1}^n \sum_{\substack{j=1 \\ j>i}}^n \frac{q_i q_j}{z_{ij}}. \quad (2.40)$$

The stipulation $j > i$ is just to remind you not to count the same pair twice. A nicer way to accomplish the same purpose is *intentionally* to count each pair twice, and then divide by 2:

$$W = \frac{1}{8\pi\epsilon_0} \sum_{i=1}^n \sum_{\substack{j=1 \\ j \neq i}}^n \frac{q_i q_j}{z_{ij}} \quad (2.41)$$

(we must still avoid $i = j$, of course). Notice that in this form the answer plainly does not depend on the *order* in which you assemble the charges, since every pair occurs in the sum. Let me next pull out the factor q_i :

$$W = \frac{1}{2} \sum_{i=1}^n q_i \left(\sum_{\substack{j=1 \\ j \neq i}}^n \frac{1}{4\pi\epsilon_0 z_{ij}} q_j \right).$$

The term in parentheses is the potential at point \mathbf{r}_i (the position of q_i) due to all the other charges—all of them, now, not just the ones that were present at some stage in the building-up process. Thus,

$$W = \frac{1}{2} \sum_{i=1}^n q_i V(\mathbf{r}_i). \quad (2.42)$$

That's how much work it takes to assemble a configuration of point charges; it's also the amount of work you'd get back out if you dismantled the system. In the meantime, it

represents energy stored in the configuration ("potential" energy, if you like, though for obvious reasons I prefer to avoid that word in this context).

Problem 2.31

(a) Three charges are situated at the corners of a square (side a), as shown in Fig. 2.41. How much work does it take to bring in another charge, $+q$, from far away and place it in the fourth corner?

(b) How much work does it take to assemble the whole configuration of four charges?

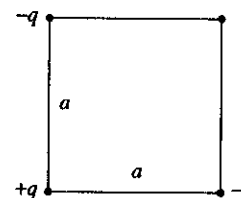

Figure 2.41

2.4.3 The Energy of a Continuous Charge Distribution

For a volume charge density ρ , Eq. 2.42 becomes

$$W = \frac{1}{2} \int \rho V d\tau. \quad (2.43)$$

(The corresponding integrals for line and surface charges would be $\int \lambda V dl$ and $\int \sigma V da$, respectively.) There is a lovely way to rewrite this result, in which ρ and V are eliminated in favor of \mathbf{E} . First use Gauss's law to express ρ in terms of \mathbf{E} :

$$\rho = \epsilon_0 \nabla \cdot \mathbf{E}, \quad \text{so} \quad W = \frac{\epsilon_0}{2} \int (\nabla \cdot \mathbf{E}) V d\tau.$$

Now use integration by parts (Eq. 1.59) to transfer the derivative from \mathbf{E} to V :

$$W = \frac{\epsilon_0}{2} \left[- \int \mathbf{E} \cdot (\nabla V) d\tau + \oint V \mathbf{E} \cdot d\mathbf{a} \right].$$

But $\nabla V = -\mathbf{E}$, so

$$W = \frac{\epsilon_0}{2} \left(\int_V E^2 d\tau + \oint_S V \mathbf{E} \cdot d\mathbf{a} \right). \quad (2.44)$$

But what volume is this we're integrating over? Let's go back to the formula we started with, Eq. 2.43. From its derivation, it is clear that we should integrate over the region where the charge is located. But actually, any *larger* volume would do just as well: The extra territory we throw in will contribute nothing to the integral anyway, since $\rho = 0$ out there. With this in mind, let's return to Eq. 2.44. What happens *here*, as we enlarge the volume beyond the minimum necessary to trap all the charge? Well, the integral of E^2 can only increase (the integrand being positive); evidently the surface integral must decrease correspondingly to leave the sum intact. In fact, at large distances from the charge, E goes like $1/r^2$ and V like $1/r$, while the surface area grows like r^2 . Roughly speaking, then, the surface integral goes down like $1/r$. Please understand that Eq. 2.44 gives you the correct energy W , whatever volume you use (as long as it encloses all the charge), but the contribution from the volume integral goes up, and that of the surface integral goes down, as you take larger and larger volumes. In particular, why not integrate over *all space*? Then the surface integral goes to zero, and we are left with

$$W = \frac{\epsilon_0}{2} \int_{\text{all space}} E^2 d\tau. \quad (2.45)$$

Example 2.8

Find the energy of a uniformly charged spherical shell of total charge q and radius R .

Solution 1: Use Eq. 2.43, in the version appropriate to surface charges:

$$W = \frac{1}{2} \int \sigma V da.$$

Now, the potential at the surface of this sphere is $(1/4\pi\epsilon_0)q/R$ (a constant), so

$$W = \frac{1}{8\pi\epsilon_0} \frac{q}{R} \int \sigma da = \frac{1}{8\pi\epsilon_0} \frac{q^2}{R}.$$

Solution 2: Use Eq. 2.45. Inside the sphere $\mathbf{E} = 0$; outside,

$$\mathbf{E} = \frac{1}{4\pi\epsilon_0} \frac{q}{r^2} \hat{\mathbf{r}}, \quad \text{so} \quad E^2 = \frac{q^2}{(4\pi\epsilon_0)^2 r^4}.$$

Therefore,

$$\begin{aligned} W_{\text{tot}} &= \frac{\epsilon_0}{2(4\pi\epsilon_0)^2} \int_{\text{outside}} \left(\frac{q^2}{r^4}\right) (r^2 \sin\theta dr d\theta d\phi) \\ &= \frac{1}{32\pi^2\epsilon_0} q^2 4\pi \int_R^\infty \frac{1}{r^2} dr = \frac{1}{8\pi\epsilon_0} \frac{q^2}{R}. \end{aligned}$$

Problem 2.32 Find the energy stored in a uniformly charged solid sphere of radius R and charge q . Do it three different ways:

- Use Eq. 2.43. You found the potential in Prob. 2.21.
- Use Eq. 2.45. Don't forget to integrate over *all space*.
- Use Eq. 2.44. Take a spherical volume of radius a . Notice what happens as $a \rightarrow \infty$.

Problem 2.33 Here is a fourth way of computing the energy of a uniformly charged sphere: Assemble the sphere layer by layer, each time bringing in an infinitesimal charge dq from far away and smearing it uniformly over the surface, thereby increasing the radius. How much work dW does it take to build up the radius by an amount dr ? Integrate this to find the work necessary to create the entire sphere of radius R and total charge q .

2.4.4 Comments on Electrostatic Energy

(I) A perplexing "inconsistency." Equation 2.45 clearly implies that the energy of a stationary charge distribution is always *positive*. On the other hand, Eq. 2.42 (from which 2.45 was in fact derived), can be positive or negative. For instance, according to 2.42, the energy of two equal but opposite charges a distance z apart would be $-(1/4\pi\epsilon_0)(q^2/z)$. What's gone wrong? Which equation is correct?

The answer is that *both* equations are correct, but they pertain to slightly different situations. Equation 2.42 does not take into account the work necessary to *make* the point charges in the first place; we *started* with point charges and simply found the work required to bring them together. This is wise policy, since Eq. 2.45 indicates that the energy of a point charge is in fact *infinite*:

$$W = \frac{\epsilon_0}{2(4\pi\epsilon_0)^2} \int \left(\frac{q^2}{r^4}\right) (r^2 \sin\theta dr d\theta d\phi) = \frac{q^2}{8\pi\epsilon_0} \int_0^\infty \frac{1}{r^2} dr = \infty.$$

Equation 2.45 is more *complete*, in the sense that it tells you the *total* energy stored in a charge configuration, but Eq. 2.42 is more appropriate when you're dealing with point charges, because we prefer (for good reason!) to leave out that portion of the total energy that is attributable to the fabrication of the point charges themselves. In practice, after all, the point charges (electrons, say) are *given* to us ready-made; all we do is move them around. Since we did not put them together, and we cannot take them apart, it is immaterial how much work the process would involve. (Still, the infinite energy of a point charge is a recurring source of embarrassment for electromagnetic theory, afflicting the quantum version as well as the classical. We shall return to the problem in Chapter 11.)

Now, you may wonder where the inconsistency crept into an apparently water-tight derivation. The "flaw" lies between Eqs. 2.42 and 2.43: In the former, $V(\mathbf{r}_i)$ represents the potential due to all the *other* charges *but not* q_i , whereas in the latter, $V(\mathbf{r})$ is the *full* potential. For a continuous distribution there is no distinction, since the amount of charge *right at the point* \mathbf{r} is vanishingly small, and its contribution to the potential is zero.

(ii) **Where is the energy stored?** Equations 2.43 and 2.45 offer two different ways of calculating the same thing. The first is an integral over the charge distribution; the second is an integral over the field. These can involve completely different regions. For instance, in the case of the spherical shell (Ex. 2.8) the charge is confined to the surface, whereas the electric field is present everywhere *outside* this surface. Where is the energy, then? Is it stored in the field, as Eq. 2.45 seems to suggest, or is it stored in the charge, as Eq. 2.43 implies? At the present level, this is simply an unanswerable question: I can tell you what the total energy is, and I can provide you with several different ways to compute it, but it is unnecessary to worry about *where* the energy is located. In the context of radiation theory (Chapter 11) it is useful (and in General Relativity it is *essential*) to regard the energy as being stored in the field, with a density

$$\frac{\epsilon_0}{2} E^2 = \text{energy per unit volume.} \quad (2.46)$$

But in electrostatics one could just as well say it is stored in the charge, with a density $\frac{1}{2} \rho V$. The difference is purely a matter of bookkeeping.

(iii) **The superposition principle.** Because electrostatic energy is *quadratic* in the fields, it does *not* obey a superposition principle. The energy of a compound system is *not* the sum of the energies of its parts considered separately—there are also “cross terms”:

$$\begin{aligned} W_{\text{tot}} &= \frac{\epsilon_0}{2} \int E^2 d\tau = \frac{\epsilon_0}{2} \int (\mathbf{E}_1 + \mathbf{E}_2)^2 d\tau \\ &= \frac{\epsilon_0}{2} \int (E_1^2 + E_2^2 + 2\mathbf{E}_1 \cdot \mathbf{E}_2) d\tau \\ &= W_1 + W_2 + \epsilon_0 \int \mathbf{E}_1 \cdot \mathbf{E}_2 d\tau. \end{aligned} \quad (2.47)$$

For example, if you double the charge everywhere, you *quadruple* the total energy.

Problem 2.34 Consider two concentric spherical shells, of radii a and b . Suppose the inner one carries a charge q , and the outer one a charge $-q$ (both of them uniformly distributed over the surface). Calculate the energy of this configuration, (a) using Eq. 2.45, and (b) using Eq. 2.47 and the results of Ex. 2.8.

2.5 Conductors

2.5.1 Basic Properties

In an *insulator*, such as glass or rubber, each electron is attached to a particular atom. In a *metallic conductor*, by contrast, one or more electrons per atom are free to roam about at will through the material. (In liquid conductors such as salt water it is *ions* that do the moving.) A *perfect conductor* would be a material containing an *unlimited* supply of completely free

charges. In real life there are no perfect conductors, but many substances come amazingly close. From this definition the basic electrostatic properties of ideal conductors immediately follow:

(i) **$\mathbf{E} = 0$ inside a conductor.** Why? Because if there *were* any field, those free charges would move, and it wouldn't be *electrostatics* any more. Well . . . that's hardly a satisfactory explanation; maybe all it proves is that you can't have electrostatics when conductors are present. We had better examine what happens when you put a conductor into an external electric field \mathbf{E}_0 (Fig. 2.42). Initially, this will drive any free positive charges to the right, and negative ones to the left. (In practice it's only the negative charges—electrons—that do the moving, but when they depart the right side is left with a net positive charge—the stationary nuclei—so it doesn't really matter which charges move; the effect is the same.) When they come to the edge of the material, the charges pile up: plus on the right side, minus on the left. Now, these **induced charges** produce a field of their own, \mathbf{E}_1 , which, as you can see from the figure, is in the *opposite direction* to \mathbf{E}_0 . That's the crucial point, for it means that the field of the induced charges *tends to cancel off the original field*. Charge will continue to flow until this cancellation is complete, and the resultant field inside the conductor is precisely zero.⁷ The whole process is practically instantaneous.

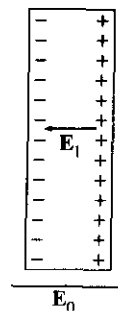

Figure 2.42

(ii) **$\rho = 0$ inside a conductor.** This follows from Gauss's law: $\nabla \cdot \mathbf{E} = \rho/\epsilon_0$. If $\mathbf{E} = 0$, so also is ρ . There is still charge around, but exactly as much plus charge as minus, so the *net* charge density in the interior is zero.

(iii) **Any net charge resides on the surface.** That's the only other place it *can* be.

(iv) **A conductor is an equipotential.** For if \mathbf{a} and \mathbf{b} are any two points within (or at the surface of) a given conductor, $V(\mathbf{b}) - V(\mathbf{a}) = -\int_{\mathbf{a}}^{\mathbf{b}} \mathbf{E} \cdot d\mathbf{l} = 0$, and hence $V(\mathbf{a}) = V(\mathbf{b})$.

⁷Outside the conductor the field is *not* zero, for here \mathbf{E}_0 and \mathbf{E}_1 do not cancel.

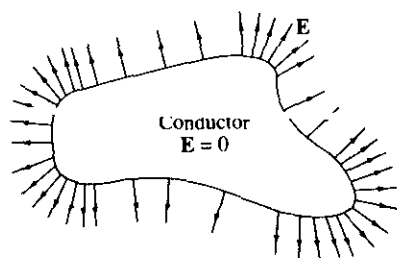

Figure 2.43

(v) \mathbf{E} is perpendicular to the surface, just outside a conductor. Otherwise, as in (i), charge will immediately flow around the surface until it kills off the tangential component (Fig. 2.43). (*Perpendicular* to the surface, charge cannot flow, of course, since it is confined to the conducting object.)

I think it is strange that the charge on a conductor flows to the surface. Because of their mutual repulsion, the charges naturally spread out as much as possible, but for *all* of them to go to the surface seems like a waste of the interior space. Surely we could do better, from the point of view of making each charge as far as possible from its neighbors, to sprinkle *some* of them throughout the volume. . . Well, it simply is not so. You do best to put *all* the charge on the surface, and this is true regardless of the size or shape of the conductor.⁸

The problem can also be phrased in terms of energy. Like any other free dynamical system, the charge on a conductor will seek the configuration that minimizes its potential energy. What property (iii) asserts is that the electrostatic energy of a solid object (with specified shape and total charge) is a minimum when that charge is spread over the surface. For instance, the energy of a sphere is $(1/8\pi\epsilon_0)(q^2/R)$ if the charge is uniformly distributed over the surface, as we found in Ex. 2.8, but it is greater, $(3/20\pi\epsilon_0)(q^2/R)$, if the charge is uniformly distributed throughout the volume (Prob. 2.32).

2.5.2 Induced Charges

If you hold a charge $+q$ near an uncharged conductor (Fig. 2.44), the two will attract one another. The reason for this is that q will pull minus charges over to the near side and repel plus charges to the far side. (Another way to think of it is that the charge moves around in such a way as to cancel off the field of q for points inside the conductor, where the total field must be zero.) Since the negative induced charge is closer to q , there is a net force of attraction. (In Chapter 3 we shall calculate this force explicitly, for the case of a spherical conductor.)

⁸By the way, the one- and two-dimensional analogs are quite different: The charge on a conducting *disk* does not all go to the perimeter (R. Friedberg, *Am. J. of Phys.* **61**, 1084 (1993)), nor does the charge on a conducting *needle* go to the ends (D. J. Griffiths and Y. Li, *Am. J. of Phys.* **64**, 706 (1996)). See Prob. 2.52.



Figure 2.44

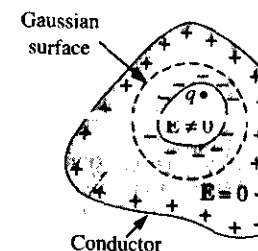

Figure 2.45

By the way, when I speak of the field, charge, or potential “inside” a conductor, I mean in the “meat” of the conductor; if there is some *cavity* in the conductor, and within that cavity there is some charge, then the field *in the cavity* will *not* be zero. But in a remarkable way the cavity and its contents are electrically isolated from the outside world by the surrounding conductor (Fig. 2.45). No external fields penetrate the conductor; they are canceled at the outer surface by the induced charge there. Similarly, the field due to charges within the cavity is killed off, for all exterior points, by the induced charge on the inner surface. (However, the compensating charge left over on the *outer* surface of the conductor effectively “communicates” the presence of q to the outside world, as we shall see in Ex. 2.9.) Incidentally, the total charge induced on the cavity wall is equal and opposite to the charge inside, for if we surround the cavity with a Gaussian surface, all points of which are in the conductor (Fig. 2.45), $\oint \mathbf{E} \cdot d\mathbf{a} = 0$, and hence (by Gauss’s law) the net enclosed charge must be zero. But $Q_{\text{enc}} = q + q_{\text{induced}}$, so $q_{\text{induced}} = -q$.

Example 2.9

An uncharged spherical conductor centered at the origin has a cavity of some weird shape carved out of it (Fig. 2.46). Somewhere within the cavity is a charge q . *Question:* What is the field outside the sphere?

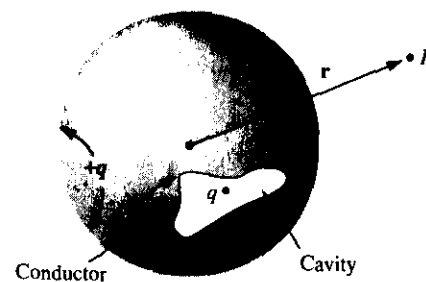

Figure 2.46

Solution: At first glance it would appear that the answer depends on the shape of the cavity and on the placement of the charge. But that's wrong: The answer is

$$\mathbf{E} = \frac{1}{4\pi\epsilon_0} \frac{q}{r^2} \hat{\mathbf{r}}$$

regardless. The conductor conceals from us all information concerning the nature of the cavity, revealing only the total charge it contains. How can this be? Well, the charge $+q$ induces an opposite charge $-q$ on the wall of the cavity, which distributes itself in such a way that its field cancels that of q , for all points exterior to the cavity. Since the conductor carries no net charge, this leaves $+q$ to distribute itself uniformly over the surface of the sphere. (It's *uniform* because the asymmetrical influence of the point charge $+q$ is negated by that of the induced charge $-q$ on the inner surface.) For points outside the sphere, then, the only thing that survives is the field of the leftover $+q$, uniformly distributed over the outer surface.

It may occur to you that in one respect this argument is open to challenge: There are actually *three* fields at work here, \mathbf{E}_q , $\mathbf{E}_{\text{induced}}$, and $\mathbf{E}_{\text{leftover}}$. All we know for certain is that the sum of the three is zero inside the conductor, yet I claimed that the first two *alone* cancel, while the third is separately zero there. Moreover, even if the first two cancel within the conductor, who is to say they still cancel for points outside? They do not, after all, cancel for points *inside* the cavity. I cannot give you a completely satisfactory answer at the moment, but this much at least is true: There *exists* a way of distributing $-q$ over the inner surface so as to cancel the field of q at all exterior points. For that same cavity could have been carved out of a *huge* spherical conductor with a radius of 27 miles or light years or whatever. In that case the leftover $+q$ on the outer surface is simply too far away to produce a significant field, and the other two fields would *have* to accomplish the cancellation by themselves. So we know they *can* do it . . . but are we sure they *choose* to? Perhaps for small spheres nature prefers some complicated three-way cancellation. Nope: As we'll see in the uniqueness theorems of Chapter 3, electrostatics is very stingy with its options; there is always precisely one way—no more—of distributing the charge on a conductor so as to make the field inside zero. Having found a *possible* way, we are guaranteed that no alternative exists even in principle.

If a cavity surrounded by conducting material is itself empty of charge, then the field within the cavity is zero. For any field line would have to begin and end on the cavity wall, going from a plus charge to a minus charge (Fig. 2.47). Letting that field line be part of a closed loop, the rest of which is entirely inside the conductor (where $\mathbf{E} = 0$), the integral

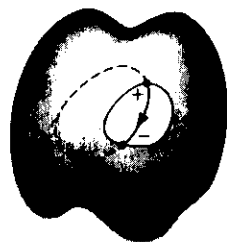

Figure 2.47

$\oint \mathbf{E} \cdot d\mathbf{l}$ is distinctly *positive*, in violation of Eq. 2.19. It follows that $\mathbf{E} = 0$ within an *empty* cavity, and there is in fact *no* charge on the surface of the cavity. (This is why you are relatively safe inside a metal car during a thunderstorm—you may get *cooked*, if lightning strikes, but you will not be *electrocuted*.) The same principle applies to the placement of sensitive apparatus inside a grounded **Faraday cage**, to shield out stray electric fields. In practice, the enclosure doesn't even have to be solid conductor—chicken wire will often suffice.)

Problem 2.35 A metal sphere of radius R , carrying charge q , is surrounded by a thick concentric metal shell (inner radius a , outer radius b , as in Fig. 2.48). The shell carries no net charge.

- Find the surface charge density σ at R , at a , and at b .
- Find the potential at the center, using infinity as the reference point.
- Now the outer surface is touched to a grounding wire, which lowers its potential to zero (same as at infinity). How do your answers to (a) and (b) change?

Problem 2.36 Two spherical cavities, of radii a and b , are hollowed out from the interior of a (neutral) conducting sphere of radius R (Fig. 2.49). At the center of each cavity a point charge is placed—call these charges q_a and q_b .

- Find the surface charges σ_a , σ_b , and σ_R .
- What is the field outside the conductor?
- What is the field within each cavity?
- What is the force on q_a and q_b ?
- Which of these answers would change if a third charge, q_c , were brought near the conductor?



Figure 2.48

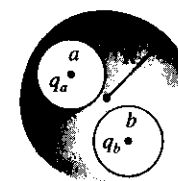

Figure 2.49

2.5.3 Surface Charge and the Force on a Conductor

Because the field inside a conductor is zero, boundary condition 2.33 requires that the field immediately *outside* is

$$\mathbf{E} = \frac{\sigma}{\epsilon_0} \hat{\mathbf{n}}, \quad (2.48)$$

consistent with our earlier conclusion that the field is normal to the surface. In terms of potential, Eq. 2.36 yields

$$\sigma = -\epsilon_0 \frac{\partial V}{\partial n}. \quad (2.49)$$

These equations enable you to calculate the surface charge on a conductor, if you can determine \mathbf{E} or V ; we shall use them frequently in the next chapter.

In the presence of an electric field, a surface charge will, naturally, experience a force; the force per unit area, \mathbf{f} , is $\sigma \mathbf{E}$. But there's a problem here, for the electric field is *discontinuous* at a surface charge, so which value are we supposed to use: $\mathbf{E}_{\text{above}}$, $\mathbf{E}_{\text{below}}$, or something in between? The answer is that we should use the *average* of the two:

$$\mathbf{f} = \sigma \mathbf{E}_{\text{average}} = \frac{1}{2} \sigma (\mathbf{E}_{\text{above}} + \mathbf{E}_{\text{below}}). \quad (2.50)$$

Why the average? The reason is very simple, though the telling makes it sound complicated: Let's focus our attention on a small patch of surface surrounding the point in question (Fig. 2.50). Make it tiny enough so it is essentially flat and the surface charge on it is essentially constant. The *total* field consists of two parts—that attributable to the patch itself, and that due to everything else (other regions of the surface, as well as any external sources that may be present):

$$\mathbf{E} = \mathbf{E}_{\text{patch}} + \mathbf{E}_{\text{other}}.$$

Now, the patch cannot exert a force on itself, any more than you can lift yourself by standing in a basket and pulling up on the handles. The force on the patch, then, is due exclusively to $\mathbf{E}_{\text{other}}$, and *this* suffers *no* discontinuity (if we removed the patch, the field in the "hole" would be perfectly smooth). The discontinuity is due entirely to the charge on the patch,

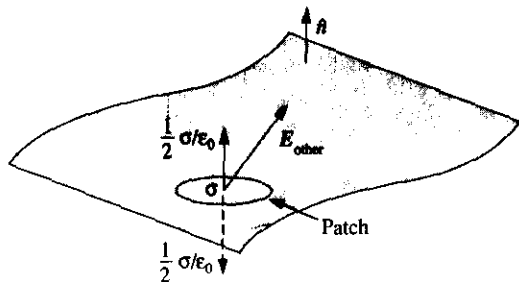

Figure 2.50

2.5. CONDUCTORS

which puts out a field $(\sigma/2\epsilon_0)$ on either side, pointing away from the surface (Fig. 2.50). Thus,

$$\mathbf{E}_{\text{above}} = \mathbf{E}_{\text{other}} + \frac{\sigma}{2\epsilon_0} \hat{\mathbf{n}},$$

$$\mathbf{E}_{\text{below}} = \mathbf{E}_{\text{other}} - \frac{\sigma}{2\epsilon_0} \hat{\mathbf{n}},$$

and hence

$$\mathbf{E}_{\text{other}} = \frac{1}{2} (\mathbf{E}_{\text{above}} + \mathbf{E}_{\text{below}}) = \mathbf{E}_{\text{average}}.$$

Averaging is really just a device for removing the contribution of the patch itself.

That argument applies to *any* surface charge; in the particular case of a conductor, the field is zero inside and $(\sigma/\epsilon_0)\hat{\mathbf{n}}$ outside (Eq. 2.48), so the average is $(\sigma/2\epsilon_0)\hat{\mathbf{n}}$, and the force per unit area is

$$\mathbf{f} = \frac{1}{2\epsilon_0} \sigma^2 \hat{\mathbf{n}}. \quad (2.51)$$

This amounts to an outward **electrostatic pressure** on the surface, tending to draw the conductor into the field, regardless of the sign of σ . Expressing the pressure in terms of the field just outside the surface,

$$P = \frac{\epsilon_0}{2} E^2. \quad (2.52)$$

Problem 2.37 Two large metal plates (each of area A) are held a distance d apart. Suppose we put a charge Q on each plate; what is the electrostatic pressure on the plates?

Problem 2.38 A metal sphere of radius R carries a total charge Q . What is the force of repulsion between the "northern" hemisphere and the "southern" hemisphere?

2.5.4 Capacitors

Suppose we have *two* conductors, and we put charge $+Q$ on one and $-Q$ on the other (Fig. 2.51). Since V is constant over a conductor, we can speak unambiguously of the potential difference between them:

$$V = V_+ - V_- = - \int_{(-)}^{(+)} \mathbf{E} \cdot d\mathbf{l}.$$

We don't know how the charge distributes itself over the two conductors, and calculating the field would be a mess, if their shapes are complicated, but this much we *do* know: \mathbf{E} is *proportional* to Q . For \mathbf{E} is given by Coulomb's law:

$$\mathbf{E} = \frac{1}{4\pi\epsilon_0} \int \frac{\rho}{r^2} \hat{\mathbf{r}} d\tau,$$



Figure 2.51

so if you double ρ , you double E . (Wait a minute! How do we know that doubling Q (and also $-Q$) simply doubles ρ ? Maybe the charge *moves around* into a completely different configuration, quadrupling ρ in some places and halving it in others, just so the *total* charge on each conductor is doubled. The *fact* is that this concern is unwarranted—doubling Q *does* double ρ everywhere; it *doesn't* shift the charge around. The proof of this will come in Chapter 3; for now you'll just have to believe me.)

Since E is proportional to Q , so also is V . The constant of proportionality is called the **capacitance** of the arrangement:

$$C \equiv \frac{Q}{V}. \quad (2.53)$$

Capacitance is a purely geometrical quantity, determined by the sizes, shapes, and separation of the two conductors. In SI units, C is measured in **farads** (F); a farad is a coulomb-per-volt. Actually, this turns out to be inconveniently large;⁹ more practical units are the microfarad (10^{-6} F) and the picofarad (10^{-12} F).

Notice that V is, by definition, the potential of the *positive* conductor less that of the negative one; likewise, Q is the charge of the *positive* conductor. Accordingly, capacitance is an intrinsically positive quantity. (By the way, you will occasionally hear someone speak of the capacitance of a *single* conductor. In this case the “second conductor,” with the negative charge, is an imaginary spherical shell of infinite radius surrounding the one conductor. It contributes nothing to the field, so the capacitance is given by Eq. 2.53, where V is the potential with infinity as the reference point.)

Example 2.10

Find the capacitance of a “parallel-plate capacitor” consisting of two metal surfaces of area A held a distance d apart (Fig. 2.52).

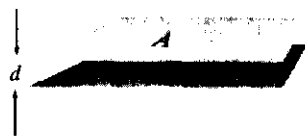

Figure 2.52

⁹In the second edition I claimed you would need a forklift to carry a 1 F capacitor. This is no longer the case—you can now buy a 1 F capacitor that fits comfortably in a soup spoon.

Solution: If we put $+Q$ on the top and $-Q$ on the bottom, they will spread out uniformly over the two surfaces, provided the area is reasonably large and the separation distance small.¹⁰ The surface charge density, then, is $\sigma = Q/A$ on the top plate, and so the field, according to Eq. 2.5 is $(1/\epsilon_0)Q/A$. The potential difference between the plates is therefore

$$V = \frac{Q}{A\epsilon_0}d,$$

and hence

$$C = \frac{A\epsilon_0}{d}. \quad (2.54)$$

If, for instance, the plates are square with sides 1 cm long, and they are held 1 mm apart, then the capacitance is 9×10^{-13} F.

Example 2.11

Find the capacitance of two concentric spherical metal shells, with radii a and b .

Solution: Place charge $+Q$ on the inner sphere, and $-Q$ on the outer one. The field between the spheres is

$$\mathbf{E} = \frac{1}{4\pi\epsilon_0} \frac{Q}{r^2} \hat{\mathbf{r}},$$

so the potential difference between them is

$$V = - \int_b^a \mathbf{E} \cdot d\mathbf{l} = - \frac{Q}{4\pi\epsilon_0} \int_b^a \frac{1}{r^2} dr = \frac{Q}{4\pi\epsilon_0} \left(\frac{1}{a} - \frac{1}{b} \right).$$

As promised, V is proportional to Q ; the capacitance is

$$C = \frac{Q}{V} = 4\pi\epsilon_0 \frac{ab}{(b-a)}.$$

To “charge up” a capacitor, you have to remove electrons from the positive plate and carry them to the negative plate. In doing so you fight against the electric field, which is pulling them back toward the positive conductor and pushing them away from the negative one. How much work does it take, then, to charge the capacitor up to a final amount Q ? Suppose that at some intermediate stage in the process the charge on the positive plate is q , so that the potential difference is q/C . According to Eq. 2.38, the work you must do to transport the next piece of charge, dq , is

$$dW = \left(\frac{q}{C} \right) dq.$$

¹⁰The exact solution is not easy—even for the simpler case of circular plates. See G. T. Carlson and B. L. Ilman, *Am. J. Phys.* **62**, 1099 (1994).

The total work necessary, then, to go from $q = 0$ to $q = Q$, is

$$W = \int_0^Q \left(\frac{q}{C}\right) dq = \frac{1}{2} \frac{Q^2}{C},$$

or, since $Q = CV$,

$$W = \frac{1}{2} CV^2, \quad (2.55)$$

where V is the final potential of the capacitor.

Problem 2.39 Find the capacitance per unit length of two coaxial metal cylindrical tubes, of radii a and b (Fig. 2.53).



Figure 2.53

Problem 2.40 Suppose the plates of a parallel-plate capacitor move closer together by an infinitesimal distance ϵ , as a result of their mutual attraction.

(a) Use Eq. 2.52 to express the amount of work done by electrostatic forces, in terms of the field E , and the area of the plates, A .

(b) Use Eq. 2.46 to express the energy lost by the field in this process.

(This problem is supposed to be easy, but it contains the embryo of an alternative derivation of Eq. 2.52, using conservation of energy.)

More Problems on Chapter 2

Problem 2.41 Find the electric field at a height z above the center of a square sheet (side a) carrying a uniform surface charge σ . Check your result for the limiting cases $a \rightarrow \infty$ and $z \gg a$.

[Answer: $(\sigma/2\epsilon_0)\{(4/\pi) \tan^{-1} \sqrt{1 + (a^2/2z^2)} - 1\}$]

Problem 2.42 If the electric field in some region is given (in spherical coordinates) by the expression

$$\mathbf{E}(\mathbf{r}) = \frac{A \hat{r} + B \sin \theta \cos \phi \hat{\phi}}{r},$$

where A and B are constants, what is the charge density? [Answer: $\epsilon_0(A - B \sin \phi)/r^2$]

Problem 2.43 Find the net force that the southern hemisphere of a uniformly charged sphere exerts on the northern hemisphere. Express your answer in terms of the radius R and the total charge Q . [Answer: $(1/4\pi\epsilon_0)(3Q^2/16R^2)$]

Problem 2.44 An inverted hemispherical bowl of radius R carries a uniform surface charge density σ . Find the potential difference between the "north pole" and the center. [Answer: $(R\sigma/2\epsilon_0)(\sqrt{2} - 1)$]

Problem 2.45 A sphere of radius R carries a charge density $\rho(r) = kr$ (where k is a constant). Find the energy of the configuration. Check your answer by calculating it in at least two different ways. [Answer: $\pi k^2 R^7/7\epsilon_0$]

Problem 2.46 The electric potential of some configuration is given by the expression

$$V(\mathbf{r}) = A \frac{e^{-\lambda r}}{r},$$

where A and λ are constants. Find the electric field $\mathbf{E}(\mathbf{r})$, the charge density $\rho(r)$, and the total charge Q . [Answer: $\rho = \epsilon_0 A (4\pi \delta^3(\mathbf{r}) - \lambda^2 e^{-\lambda r}/r)$]

Problem 2.47 Two infinitely long wires running parallel to the x axis carry uniform charge densities $+\lambda$ and $-\lambda$ (Fig. 2.54).

(a) Find the potential at any point (x, y, z) , using the origin as your reference.

(b) Show that the equipotential surfaces are circular cylinders, and locate the axis and radius of the cylinder corresponding to a given potential V_0 .

Problem 2.48 In a vacuum diode, electrons are "boiled" off a hot cathode, at potential zero, and accelerated across a gap to the anode, which is held at positive potential V_0 . The cloud of moving electrons within the gap (called space charge) quickly builds up to the point where it reduces the field at the surface of the cathode to zero. From then on a steady current I flows between the plates.

Suppose the plates are large relative to the separation ($A \gg d^2$ in Fig. 2.55), so that edge effects can be neglected. Then V , ρ , and v (the speed of the electrons) are all functions of x alone.

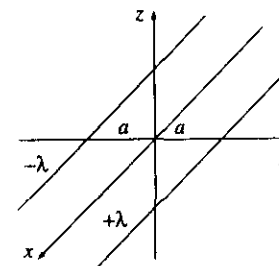

Figure 2.54

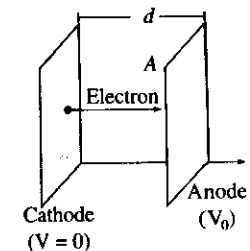

Figure 2.55

- (a) Write Poisson's equation for the region between the plates.
 (b) Assuming the electrons start from rest at the cathode, what is their speed at point x , where the potential is $V(x)$?
 (c) In the steady state, I is independent of x . What, then, is the relation between ρ and v ?
 (d) Use these three results to obtain a differential equation for V , by eliminating ρ and v .
 (e) Solve this equation for V as a function of x , V_0 , and d . Plot $V(x)$, and compare it to the potential *without* space-charge. Also, find ρ and v as functions of x .
 (f) Show that

$$I = K V_0^{3/2}, \quad (2.56)$$

and find the constant K . (Equation 2.56 is called the **Child-Langmuir law**. It holds for other geometries as well, whenever space-charge limits the current. Notice that the space-charge limited diode is *nonlinear*—it does not obey Ohm's law.)

Problem 2.49 Imagine that new and extraordinarily precise measurements have revealed an error in Coulomb's law. The *actual* force of interaction between two point charges is found to be

$$\mathbf{F} = \frac{1}{4\pi\epsilon_0} \frac{q_1 q_2}{r^2} \left(1 + \frac{r}{\lambda}\right) e^{-r/\lambda} \hat{\mathbf{r}},$$

where λ is a new constant of nature (it has dimensions of length, obviously, and is a huge number—say half the radius of the known universe—so that the correction is small, which is why no one ever noticed the discrepancy before). You are charged with the task of reformulating electrostatics to accommodate the new discovery. Assume the principle of superposition still holds.

- (a) What is the electric field of a charge distribution ρ (replacing Eq. 2.8)?
 (b) Does this electric field admit a scalar potential? Explain briefly how you reached your conclusion. (No formal proof necessary—just a persuasive argument.)
 (c) Find the potential of a point charge q —the analog to Eq. 2.26. (If your answer to (b) was “no,” better go back and change it!) Use ∞ as your reference point.
 (d) For a point charge q at the origin, show that

$$\oint_S \mathbf{E} \cdot d\mathbf{a} + \frac{1}{\lambda^2} \int_V V d\tau = \frac{1}{\epsilon_0} q,$$

where S is the surface, V the volume, of any sphere centered at q .

- (e) Show that this result generalizes:

$$\oint_S \mathbf{E} \cdot d\mathbf{a} + \frac{1}{\lambda^2} \int_V V d\tau = \frac{1}{\epsilon_0} Q_{\text{enc.}}$$

for any charge distribution. (This is the next best thing to Gauss's Law, in the new “electrostatics.”)

- (f) Draw the triangle diagram (like Fig. 2.35) for this world, putting in all the appropriate formulas. (Think of Poisson's equation as the formula for ρ in terms of V , and Gauss's law (differential form) as an equation for ρ in terms of \mathbf{E} .)

Problem 2.50 Suppose an electric field $\mathbf{E}(x, y, z)$ has the form

$$E_x = ax, \quad E_y = 0, \quad E_z = 0$$

where a is a constant. What is the charge density? How do you account for the fact that the field points in a particular direction, when the charge density is uniform? [This is a more subtle problem than it looks, and worthy of careful thought.]

Problem 2.51 All of electrostatics follows from the $1/r^2$ character of Coulomb's law, together with the principle of superposition. An analogous theory can therefore be constructed for Newton's law of universal gravitation. What is the gravitational energy of a sphere, of mass M and radius R , assuming the density is uniform? Use your result to estimate the gravitational energy of the sun (look up the relevant numbers). The sun radiates at a rate of 3.86×10^{26} W; if all this came from stored gravitational energy, how long would the sun last? [The sun is in fact much older than that, so evidently this is *not* the source of its power.]

Problem 2.52 We know that the charge on a conductor goes to the surface, but just how it distributes itself there is not easy to determine. One famous example in which the surface charge density can be calculated explicitly is the ellipsoid:

$$\frac{x^2}{a^2} + \frac{y^2}{b^2} + \frac{z^2}{c^2} = 1.$$

In this case¹¹

$$\sigma = \frac{Q}{4\pi abc} \left(\frac{x^2}{a^4} + \frac{y^2}{b^4} + \frac{z^2}{c^4} \right)^{-1/2}. \quad (2.57)$$

where Q is the total charge. By choosing appropriate values for a , b , and c , obtain (from Eq. 2.57): (a) the net (both sides) surface charge density $\sigma(r)$ on a circular disk of radius R ; (b) the net surface charge density $\sigma(x)$ on an infinite conducting “ribbon” in the x y plane, which straddles the y axis from $x = -a$ to $x = a$ (let Λ be the total charge per unit length of ribbon); (c) the net charge per unit length $\lambda(x)$ on a conducting “needle”, running from $x = -a$ to $x = a$. In each case, sketch the graph of your result.

¹¹For the derivation (which is a real *tour de force*) see W. R. Smythe, *Static and Dynamic Electricity*, 3rd ed. (New York: Hemisphere, 1989), Sect. 5.02.