

Figure 9.1 Intensity  $I_\lambda$ .

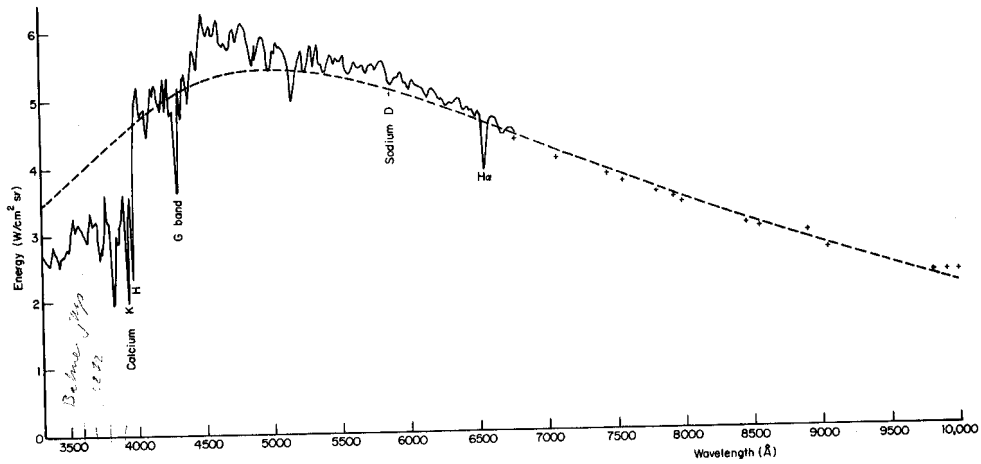

Figure 9.5 The spectrum of the Sun. The dashed line is the curve of an ideal blackbody having the Sun's effective temperature. (Figure from Aller, *Atoms, Stars, and Nebulae*, Revised Edition, Harvard University Press, Cambridge, MA, 1971.)

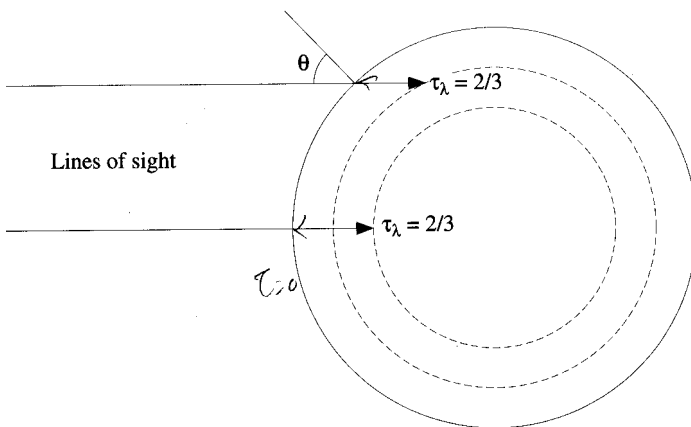

Figure 9.12 Limb darkening.

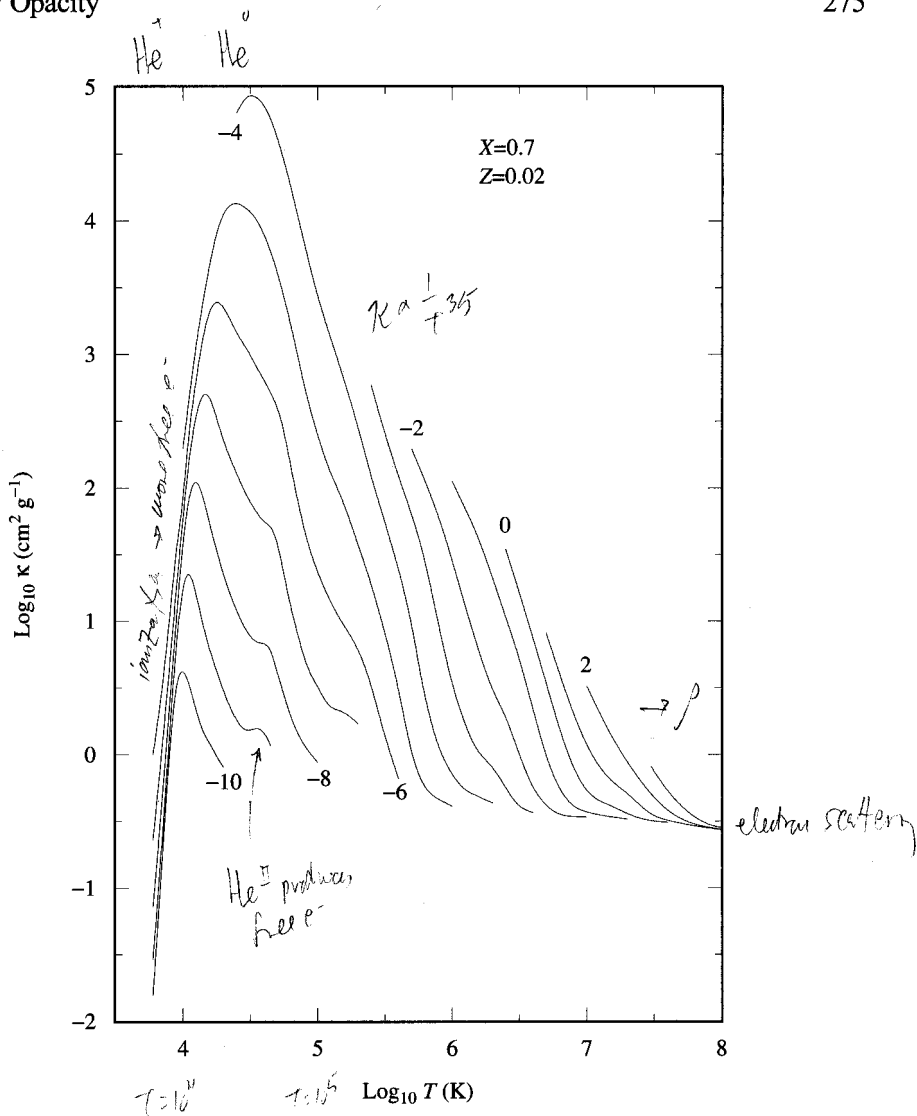

Figure 9.10 Rosseland mean opacity. The curves are labeled by the value of the density ( $\log_{10} \rho$  in  $\text{g cm}^{-3}$ ). (Data from Rogers and Iglesias, *Ap. J. Suppl.*, 79, 507, 1992.)

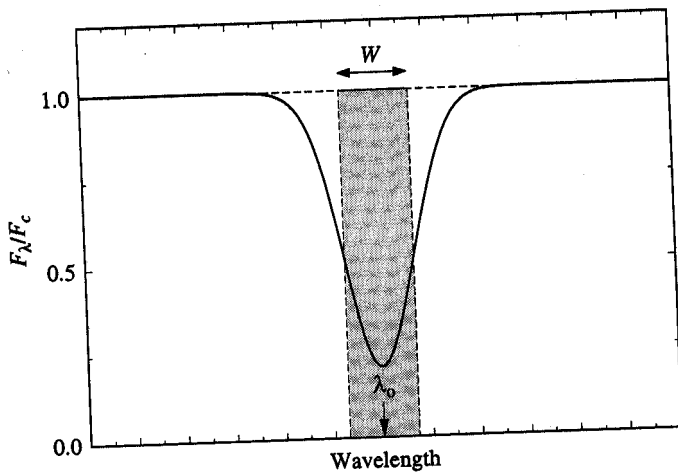

Figure 9.18 The shape of a typical spectral line.